

DeltaSol® MX

Beginning with firmware version 2.07

RESOL®

System controller for complex solar and heating systems

Manual for the specialised craftsman

Installation

Operation

Functions and options

Troubleshooting

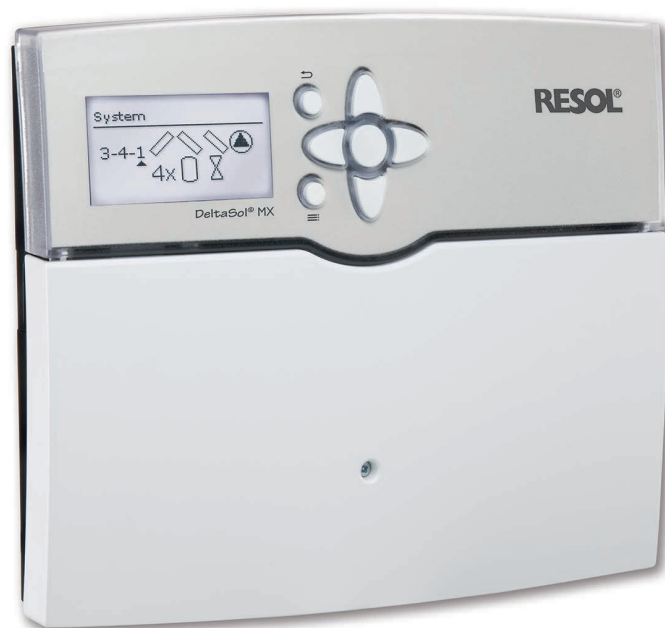

11213441



The Internet portal for easy and secure access to your system data – www.vbus.net

Thank you for buying this RESOL product.

Please read this manual carefully to get the best performance from this unit. Please keep this manual safe.

en

Manual

www.resol.com

Safety advice

Please pay attention to the following safety advice in order to avoid danger and damage to people and property.

Danger of electric shock:

- When carrying out works, the device must first of all be disconnected from the mains.
- It must be possible to disconnect the device from the mains at any time.
- Do not use the device if it is visibly damaged!

Instructions

Attention must be paid to the valid local standards, regulations and directives!

Information about the product

Proper usage

The system controller is designed for electronically controlling solar thermal systems and heating systems in compliance with the technical data specified in this manual.

Improper use excludes all liability claims.

EU Declaration of conformity

The product complies with the relevant directives and is therefore labelled with the CE mark. The Declaration of Conformity is available upon request, please contact the manufacturer.



Note

Strong electromagnetic fields can impair the function of the controller.

- ➔ Make sure the controller as well as the system are not exposed to strong electromagnetic fields.

Subject to technical change. Errors excepted.

Target group

These instructions are exclusively addressed to authorised skilled personnel.

Only qualified electricians are allowed to carry out electrical works.

Initial commissioning must be effected by authorised skilled personnel.

Authorised skilled personnel are persons who have theoretical knowledge and experience with the installation, commissioning, operation, maintenance, etc. of electric/electronic devices and hydraulic systems and who have knowledge of relevant standards and directives.

Description of symbols

Warnings are indicated with a warning symbol!

Signal words describe the danger that may occur, when it is not avoided.

WARNING

means that injury, possibly life-threatening injury, can occur.

- ➔ It is indicated how to avoid the danger described.



ATTENTION

means that damage to the appliance can occur.

- ➔ It is indicated how to avoid the danger described.



Note

Notes are indicated with an information symbol.

- ➔ Arrows indicate instruction steps that should be carried out.

Disposal

- Dispose of the packaging in an environmentally sound manner.
- At the end of its working life, the product must not be disposed of as urban waste. Old appliances must be disposed of by an authorised body in an environmentally sound manner. Upon request we will take back your old appliances bought from us and guarantee an environmentally sound disposal of the devices.



The *DeltaSol*® MX is the most versatile system controller for complex solar and heating systems in our product range. It is ideal to control a combination of solar and non-solar parts of the system.

Easy combination and parameterisation of pre-programmed functions for several millions of hydraulic variants.

Contents

| | | | |
|--|-----------|---------------------------------|-----------|
| 1 Overview | 4 | 8 Solar | 47 |
| 2 Installation | 5 | 8.1 Basic setting | 47 |
| 2.1 Mounting | 5 | 8.2 Optional functions | 50 |
| 2.2 Electrical connection | 7 | 8.3 Function control | 60 |
| 2.3 Data communication / Bus | 9 | 8.4 Holiday function | 61 |
| 2.4 SD card slot | 9 | 8.5 Solar expert menu | 62 |
| 3 Step-by-step parameterisation | 9 | 9 Arrangement | 63 |
| 4 Operation and function | 10 | 9.1 Optional functions | 63 |
| 4.1 Buttons | 10 | 10 Heating | 71 |
| 4.2 Selecting menu points and adjusting values | 10 | 10.1 Shared relays | 71 |
| 4.3 Adjusting the timer | 12 | 10.2 Heating circuits | 73 |
| 4.4 Adjusting optional functions | 14 | 10.3 Optional functions | 82 |
| 4.5 Output submenu | 16 | 10.4 Screed drying | 86 |
| 4.6 Sensor configuration | 18 | 11 HQM | 87 |
| 5 Commissioning | 19 | 12 Basic settings | 89 |
| 5.1 Basic systems | 20 | 13 SD card | 89 |
| 5.2 Overview of output and sensor allocation | 21 | 14 Manual mode | 90 |
| 6 Main menu | 44 | 15 User code | 91 |
| 6.1 Menu structure | 45 | 16 Inputs/Modules | 91 |
| 7 Status | 46 | 16.1 Modules | 91 |
| 7.1 Measured / Balance values | 46 | 16.2 Inputs | 91 |
| 7.2 Solar | 46 | 17 Troubleshooting | 93 |
| 7.3 Arrangement | 46 | 18 Accessories | 96 |
| 7.4 Heating | 46 | 19 Index | 98 |
| 7.5 HQM | 46 | | |
| 7.6 Messages | 46 | | |
| 7.7 Home screen | 47 | | |

1 Overview

- 14 relay outputs and 12 inputs for Pt1000, Pt500 or KTY temperature sensors
- Up to 5 extension modules via VBus® (45 sensors and 39 relays in total)
- Inputs for analogue and digital Grundfos Direct Sensors™ as well as for FRH and FRHd humidity sensors
- Integrated control of up to 4 high-efficiency pumps via PWM outputs
- Data logging, storing, easy transfer of controller adjustments prepared and firmware updates via SD card
- Cooling over the heating circuit with condensation detection
- Dew point calculation by means of the FRH(d) humidity sensor to avoid condensation
- Simplified timer, 0-10V boiler control and DHW preheating
- Remote access to the heating circuits with room control unit(s) or the VBus®Touch HC App
- Extended optional functions, e.g. solid fuel boiler function with mixer and target temperature control

Technical data

Inputs: 12 Pt1000, Pt500 or KTY temperature sensor inputs (can optionally be used for remote controls, operating mode switches or potential-free switches), 3 impulse inputs for V40 flowmeters (can optionally be used for Pt1000, Pt500 or KTY temperature sensors, remote controls, operating mode switches or potential-free switches), 1 frequency input, 1 CS10 solar cell, 2 analogue inputs for VFS/RPS Grundfos Direct Sensors™ or FRH humidity sensors, 2 digital inputs for VFD/RPD Grundfos Direct Sensors™ or FRHd humidity sensors

Outputs: 14 relays, 13 of them semiconductor relays for speed control, 1 potential-free relay, 4 PWM outputs (switchable to 0-10V)

PWM frequency: 512 Hz

PWM voltage: 10.5V

Switching capacity:

1 (1) A 240 V~ (semiconductor relay)

4 (2) A 24 V== / 240 V~ (potential-free relay)

Total switching capacity: 6.3 A 240 V~

Power supply: 100–240 V~ (50–60 Hz)

Supply connection: type X attachment

Standby: 0.82 W

Temperature controls class: VIII

Energy efficiency contribution: 5%

Mode of operation: type 1.B.C.Y action

Rated impulse voltage: 2.5 kV

Data interface: VBus®, SD card slot

VBus® current supply: 35 mA

Functions: 7 integrated calorimeters and control of weather-compensated heating circuits. Adjustable system parameters and add-on options (menu-driven), balance and diagnostics functions, function control according to VDI 2169

Housing: plastic, PC-ABS and PMMA

Mounting: wall mounting, also suitable for mounting into patch panels

Indication / Display: full graphic display

Operation: 7 buttons

Ingress protection: IP 20/EN 60529

Protection class: I

Ambient temperature: 0... 40°C

Degree of pollution: 2

Dimensions: 253 × 200 × 47 mm

Dimensions and minimum distances

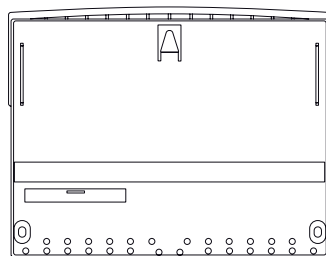
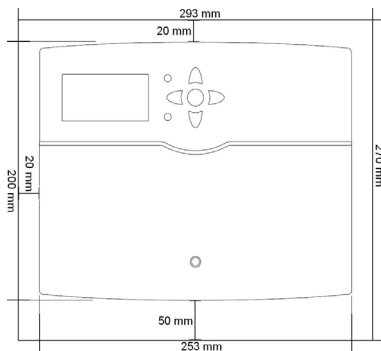

2 Installation

2.1 Mounting

WARNING! Danger of electric shock!

Upon opening the housing, live parts are exposed!

→ **Always disconnect the device from power supply before opening the housing!**



Note

Strong electromagnetic fields can impair the function of the device.

→ Make sure the device as well as the system are not exposed to strong electromagnetic fields.

The device must only be located in dry interior rooms.

If the device is not equipped with a mains connection cable and a plug, the device must additionally be supplied from a double pole switch with contact gap of at least 3 mm.

Please pay attention to separate routing of sensor cables and mains cables.

In order to mount the device to the wall, carry out the following steps:

- Unscrew the crosshead screw from the cover and remove it along with the cover from the housing.
- Mark the upper fastening point on the wall. Drill and fasten the enclosed wall plug and screw leaving the head protruding.
- Hang the housing from the upper fastening point and mark the lower fastening points (centres 233 mm).
- Insert lower wall plugs.
- Fasten the housing to the wall with the lower fastening screws and tighten.
- Carry out the electrical wiring in accordance with the terminal allocation (see page 7).
- Put the cover on the housing.
- Attach with the crosshead screw.

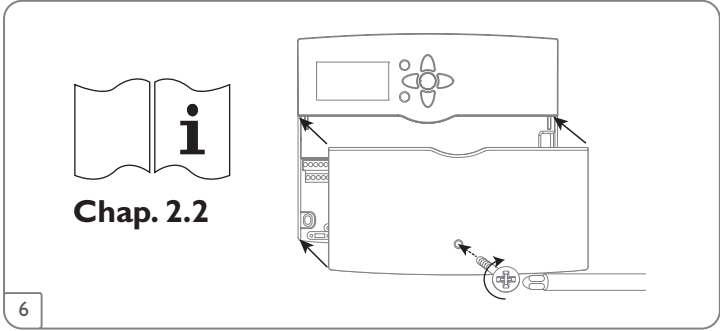
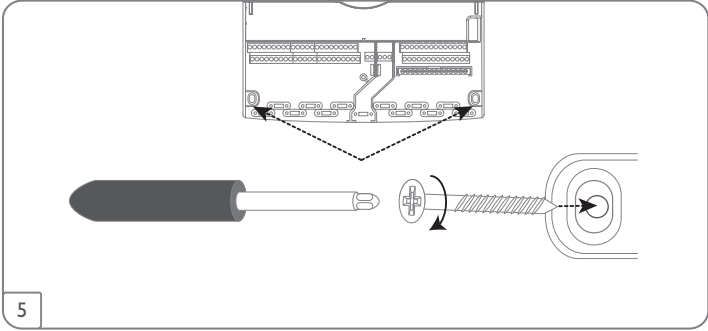
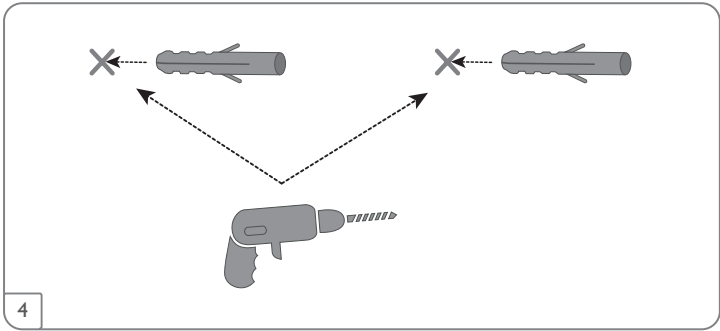
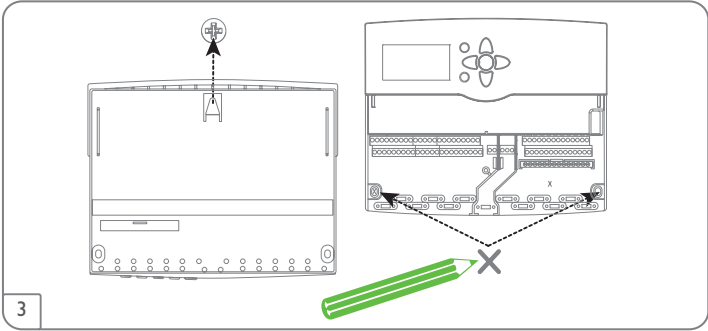
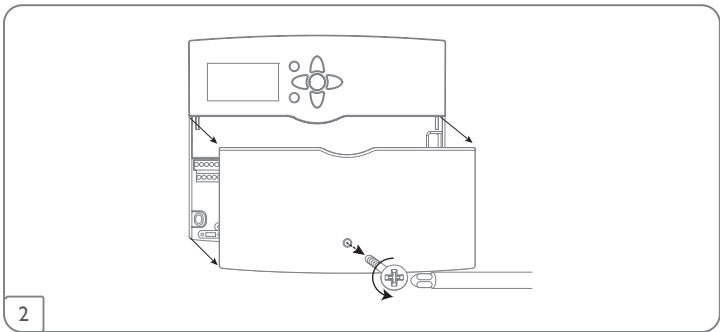
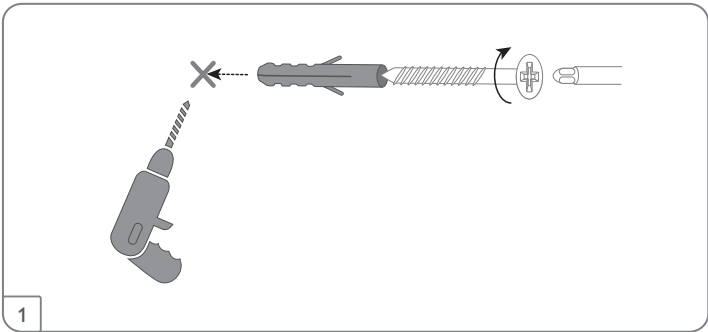

2.2 Electrical connection

WARNING! Danger of electric shock!



Upon opening the housing, live parts are exposed!

→ Always disconnect the device from power supply before opening the housing!

ATTENTION! ESD damage!



Electrostatic discharge can lead to damage to electronic components!

→ Take care to discharge properly before touching the inside of the device! To do so, touch a grounded surface such as a radiator or tap!



Note

Connecting the device to the power supply must always be the last step of the installation!



Note

The **Speed** option must be set to **Off** when non-speed-controlled devices such as valves are connected.



Note

It must be possible to disconnect the device from the mains at any time.

→ Install the mains plug so that it is accessible at any time.

→ If this is not possible, install a switch that can be accessed.

If the mains cable is damaged, it must be replaced by a special connection cable which is available from the manufacturer or its customer service.

Do not use the device if it is visibly damaged!

The controller is equipped with 14 relays in total to which loads such as pumps, valves, etc. can be connected:

Relays 1 ... 13 are semiconductor relays, designed for pump speed control:

Conductor R1 ... R13

Neutral conductor N (common terminal block)

Protective earth conductor \oplus (common terminal block)

Relay 14 is a potential-free relay:

R14-A = normally open contact

R14-M = centre contact

R14-R = normally closed contact

Depending on the product version, mains cables and sensor cables are already connected to the device. If that is not the case, please proceed as follows:

Attach flexible cables to the housing with the enclosed strain relief and the corresponding screws.

The **temperature sensors** (S1 to S12) have to be connected to the terminals S1 to S12 and GND (either polarity).

The cables carry low voltage and must not run together in a cable conduit with cables carrying a voltage higher than 50 V (please pay attention to the valid local regulations). The cable lengths depend on the cross sectional area.

Example: up to 100 m at 1.5 mm², up to 50 m at 0.75 mm². The cables can be extended with a two-wire cable.

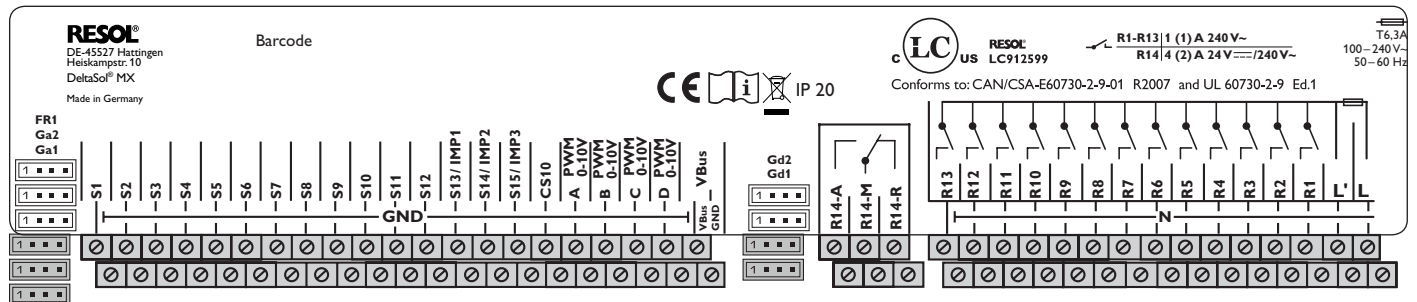

The **V40** flowmeters can be connected to the terminals S13/IMP1 to S15/IMP3 and GND (either polarity).

Connect the irradiation sensor **CS10** to the terminals CS10 and GND with correct polarity. To do so, connect the cable marked GND to the GND common terminal block, the cable marked CS to the terminal marked CS10.

The terminals marked **PWM/0-10V** are control outputs for high-efficiency pumps (for connection see illustration).

Electrical connection of a high-efficiency pump (HE pump)

Speed control of a HE pump is possible via a PWM signal / 0-10V control. The pump has to be connected to the relay (power supply) as well as to one of the PWM outputs of the controller. In the **Output** adjustment channel one of the PWM control types as well as a relay have to be selected (see page 16).

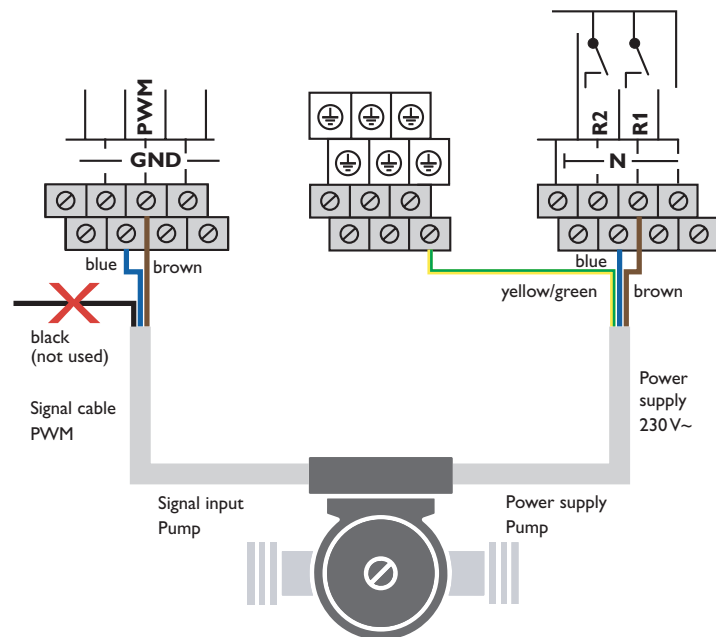

Note

When Grundfos Direct Sensors™ are used, connect the sensor ground common terminal block to PE.

Connect the **analogue Grundfos Direct Sensors™** or **FRH humidity sensors** to the Ga1 and Ga2 inputs.

Connect the **digital Grundfos Direct Sensors™** or **FRHd humidity sensors** to the Gd1 and Gd2 inputs.

Connect the flow rate sensor with frequency signal to the FR1 input.

The controller is supplied with power via a mains cable. The power supply of the device must be 100... 240V~ (50... 60 Hz).

Connect the **mains cable** to the following terminals:

Neutral conductor N

Conductor L

Protective earth conductor ⊕ (common terminal block)

WARNING! Danger of electric shock!



L' is a fused contact permanently carrying voltage.

→ **Always disconnect the device from power supply before opening the housing!**

Conductor L' (L' is not connected with the mains cable. L' is a fused contact permanently carrying voltage.)



Note

For more details about the commissioning procedure see page 9.

2.3 Data communication / Bus

The controller is equipped with a VBus® for data transfer and energy supply to external modules. The connection is to be carried out at the terminals marked **VBus** (any polarity).

One or more VBus® modules can be connected via this data bus, such as:

- DL2/DL3 Datalogger
- KM2 Communication module
- VBus®/USB or VBus®/LAN interface adapters

Different solutions for visualisation and remote parameterisation are available on the website www.resol.com. On the website, firmware updates are also available.



Note

During remote parameterisation, the  symbol will be displayed, the controller will not carry out any control function.



Note

For more information about accessories, see page 96.

2.4 SD card slot

The controller is equipped with an SD card slot.

With an SD card, the following functions can be carried out:

- Store measurement and balance values onto the SD card. After the transfer to a computer, the values can be opened and visualised, e.g. in a spreadsheet.
- Prepare adjustments and parameterisations on a computer and transfer them via the SD card.
- Store adjustments and parameterisations on the SD card and, if necessary, retrieve them from there.
- Download firmware updates from the Internet and install them on the controller.

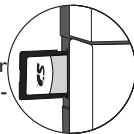

Note

For more information about using an SD card, see page 89.

3 Step-by-step parameterisation

The **DeltaSol® MX** is a controller that offers a broad variety of functions to the user. At the same time, the user has a lot of freedom in configuring them. Therefore, to set up a complex system, careful planning is required. We recommend drawing a sketch of the system first.

If planning, hydraulic construction and electrical connection have all been carried out successfully, proceed as follows:

1. Running the commissioning menu

After the commissioning menu has been finished (see page 19), further adjustments can be made. The commissioning menu can be repeated any time by means of a reset (see page 89). Additional adjustments will be deleted.

For further information about the commissioning menu see page 19.

2. Registering sensors

If flowmeters, flow switches, Grundfos Direct Sensors™, flow rate sensors, humidity sensors, room control units, remote controls, switches and/or external extension modules are connected, these have to be registered in the **Inputs/Modules** menu. For further information about the registration of modules and sensors see page 91.

In some functions, the **Sensor config.** channel is available for sensor selection, in which sensors not used and not registered can be selected. The selected sensor input will automatically be set to the sensor type required for the function.

3. Activating optional functions and/or heating circuits

The basic solar system has been adjusted during commissioning. Now, optional functions and/or heating circuits can be selected, activated and adjusted.

Outputs available can be allocated to functions which require an output. The controller always suggests the numerically smallest output available.

Sensors can be allocated to more than one function.

For further information about the solar optional functions see page 50.

For further information about the optional arrangement functions see page 63.

For further information about heating circuits and optional heating functions see page 73.

4 Operation and function

4.1 Buttons

The controller is operated via the 7 buttons next to the display. They have the following functions:

- Button 1 - scrolling upwards
- Button 3 - scrolling downwards
- Button 2 - increasing adjustment values
- Button 4 - reducing adjustment values
- Button 5 - confirming
- Button 6 - entering the status menu/chimney sweeper mode (system-dependent)
- Button 7 - escape button for changing into the previous menu/to the holidays menu (press and hold down for 5 s, see page 11)

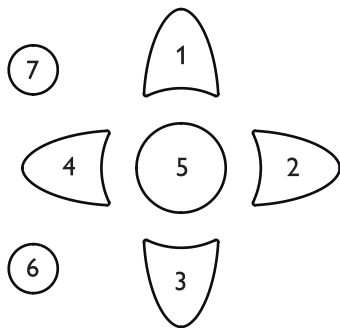

Operating control LED (in the directional pad)

- Green: Everything OK
- Red: Cancellation screed drying
- Red flashing: Sensor fault / initialisation / chimney sweeper function active
- Green flashing: Manual mode / screed drying active

4.2 Selecting menu points and adjusting values

During normal operation of the controller, the display is in the main menu. If no button is pressed for 1 min, the display illumination switches off. After 4 further minutes, the controller will display the home screen (see page 47).

Press any key to reactivate the display illumination.

- ➔ In order to scroll through a menu or to adjust a value, press either buttons 1 and 3 or buttons 2 and 4.
- ➔ To open a submenu or to confirm a value, press button 5.
- ➔ To enter the status menu, press button 6 – unconfirmed adjustments will not be saved.
- ➔ To enter the previous menu, press button 7 – unconfirmed adjustments will not be saved.

If no button has been pressed within a couple of minutes, the adjustment is cancelled and the previous value is retained.

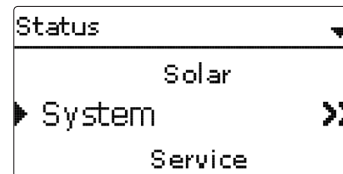

If the symbol >> is shown behind a menu item, pressing button 5 will open a new submenu.

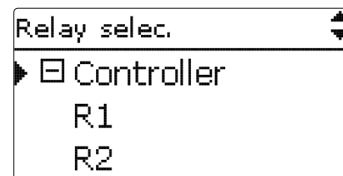

If the symbol ⊞ is shown in front of a menu item, pressing button 5 will open a new submenu. If it is already opened, a □ is shown instead of the ⊞.

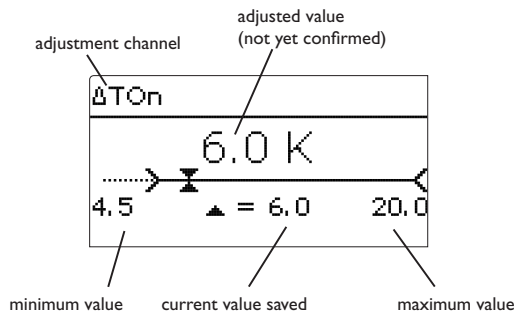

Values and options can be changed in different ways:

Numeric values can be adjusted by means of a slide bar. The minimum value is indicated to the left, the maximum value to the right. The large number above the slide bar indicates the current adjustment. By pressing buttons **2** or **4** the upper slide bar can be moved to the left or to the right.

Only after the adjustment has been confirmed by pressing button **5** will the number below the slide bar indicate the new value. The new value will be saved if it is confirmed by pressing button **5** again.

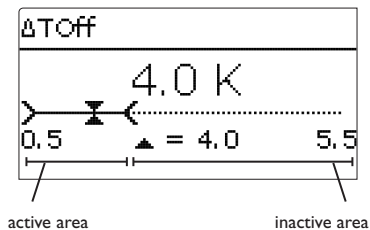

When 2 values are locked against each other, they will display a reduced adjustment range depending on the adjustment of the respective other value.

In this case, the active area of the slide bar is shortened, the inactive area is indicated as a dotted line. The indication of the minimum and maximum values will adapt to the reduction.

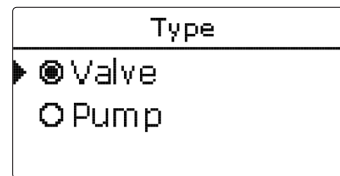

If only one item of several can be selected, they will be indicated with radio buttons. When one item has been selected, the radio button in front of it is filled.

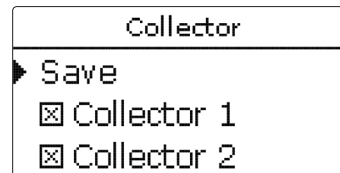

If more than one item of several can be selected, they will be indicated with checkboxes. When an item has been selected, an x appears inside the checkbox.

4.3 Adjusting the days of absence

The parameter **Days of absence** can be used for entering the number of days for an absence.

➔ In order to adjust the days of absence, press and hold down button **7** for 5 s.

For the number of days adjusted, the following functions are deactivated or modified in their behaviour respectively:

- Solar part of the system (see page 61)
- Heating circuits (see page 79)
- Thermal disinfection (see page 82)
- DHW heating (see page 83)

4.4 Adjusting the timer

When the **Timer** option is activated, a timer is indicated in which time frames for the function can be adjusted.

In the **Day selection** channel, the days of the week are available individually and as frequently selected combinations.

If more than one day or combination is selected, they will be merged into one combination for the following steps.

The last menu item after the list of days is **Continue**. If Continue is selected, the timer menu opens, in which the time frames can be adjusted.

| |
|----------------------------------|
| ▶ Day selection Reset back |
|----------------------------------|

| |
|--|
| Day selection <input type="checkbox"/> Mon-Sun <input type="checkbox"/> Mon-Fri <input type="checkbox"/> Sat-Sun <input checked="" type="checkbox"/> Mon <input type="checkbox"/> Tue <input checked="" type="checkbox"/> Wed <input type="checkbox"/> Thu <input type="checkbox"/> Fri <input type="checkbox"/> Sat <input checked="" type="checkbox"/> Sun ▶ Continue |
|--|

→ In order to save the time frame, select **Save** and confirm the security enquiry with **Yes**.

| |
|---------------|
| Stop 08:30 |
|---------------|

| |
|--|
| Mon,Wed,Sun Start 06:00 Stop 08:30 ▶ Save |
|--|

| |
|-------------------|
| Save Save? Yes |
|-------------------|

Adding a time frame:

In order to add a time frame, proceed as follows:

→ Select **New time frame**.

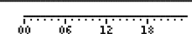
| |
|---|
| Mon,Wed,Sun  ▶ New time frame Copy from |
|---|

→ In order to add another time frame, repeat the previous steps.
6 time frames can be adjusted per day or combination.

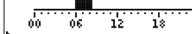
| |
|---|
| Mon,Wed,Sun  ▶ New time frame Copy from |
|---|

| |
|--|
| Mon,Wed,Sun ▶ Start --:-- Stop --:-- back |
|--|

| |
|---|
| Mon,Wed,Sun  ▶ New time frame Copy from |
|---|

→ Adjust **Start** and **Stop** for the desired time frame.
The time frames can be adjusted in steps of 5 min.

| |
|----------------|
| Start 06:00 |
|----------------|

→ Press the left button (↩) in order to get back to the day selection.

| |
|---|
| Day selection ▶ Mon,Wed,Sun Reset |
|---|

Copying a time frame:

In order to copy time frames already adjusted into another day / another combination, proceed as follows:

- ➔ Choose the day / the combination into which the time frames are to be copied and select **Copy from**.

A selection of days and / or combinations with time frames will appear:

- ➔ Select the day or combination from which the time frames are to be copied.

All time frames adjusted for the selected day or combination will be copied.

If the time frames copied are not changed, the day or combination will be added to the combination from which the time frames have been copied.

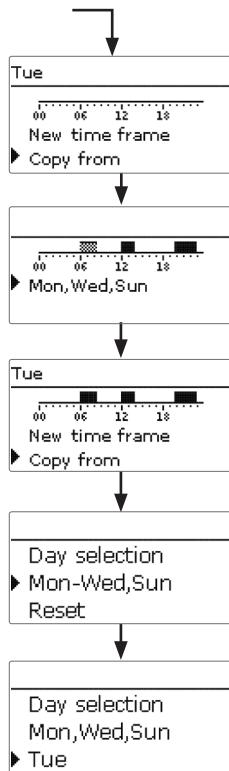

Changing a time frame:

In order to change a time frame, proceed as follows:

- ➔ Select the time frame to be changed.
- ➔ Make the desired change.

- ➔ In order to save the time frame, select **Save** and confirm the security enquiry with **Yes**.

Removing a time frame:

In order to delete a time frame, proceed as follows:

- ➔ Select the time frame that is to be deleted.
- ➔ Select **Delete** and confirm the security enquiry with **Yes**.

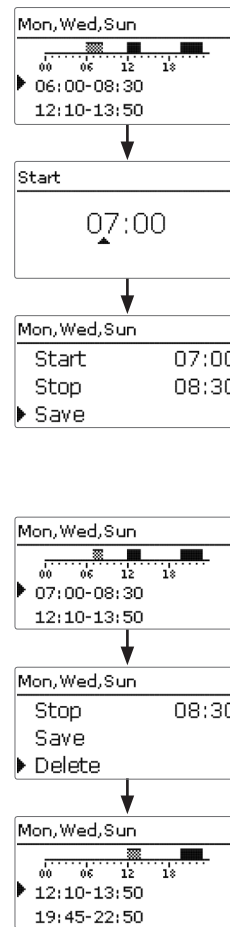

Resetting the timer:

In order to reset time frames adjusted for a certain day or combination, proceed as follows:

→ Select the desired day or combination.

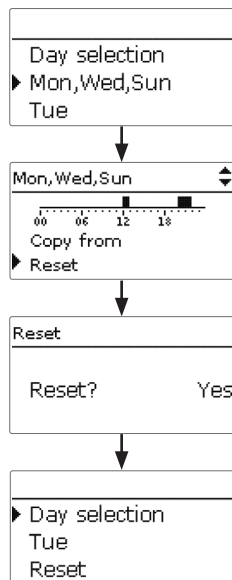

→ Select **Reset** and confirm the security enquiry with **Yes**.

The selected day or combination will disappear from the list, all its time frames will be deleted.

In order to reset the whole timer, proceed as follows:

→ Select **Reset** and confirm the security enquiry with **Yes**.

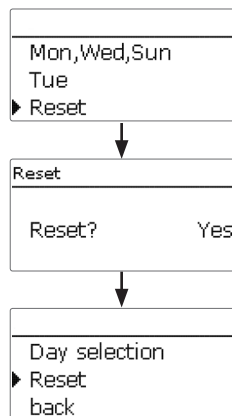

All adjustments made for the timer are deleted.

4.5 Adjusting optional functions

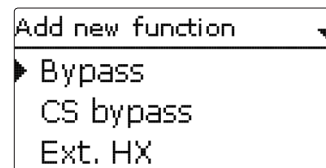

In the **Optional functions / Add new function** menus, optional functions can be selected and adjusted.

The kind and number of optional functions offered depends on the previous adjustments.

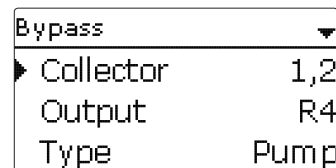

When a function is selected, a submenu opens in which all adjustments required can be made.

In this submenu, an output and, if necessary, certain system components can be allocated to the function.

If an output can be allocated to the function, the **Output** submenu opens (see page 14).

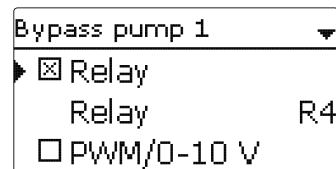

When a function has been adjusted and saved, it will appear in the **Opt. functions** menu above the menu item **Add new function**.

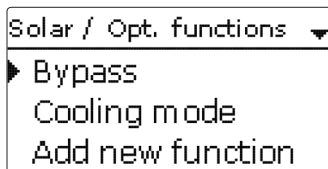

This allows an easy overview of functions already saved.

An overview about which sensor has been allocated to which component and which output has been allocated to which function is given in the **Status** menu.

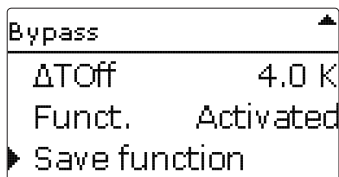

At the end of each optional function submenu, the menu items **Funct.** and **Save function** are available. In order to save a function, select **Save function** and confirm the security enquiry by selecting **Yes**.

In functions already saved, the menu item **Delete function** will appear instead.

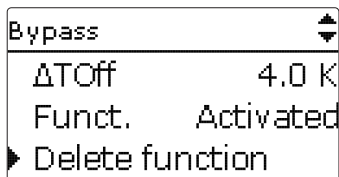

In order to delete a function already saved, select **Delete function** and confirm the security enquiry by selecting **Yes**. The function will become available under **Add new function** again. The corresponding outputs will be available again.

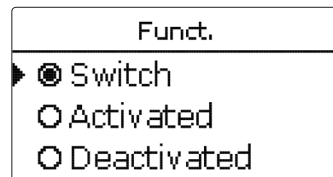

With the menu item **Funct.**, an optional function already saved can be temporarily deactivated or re-activated respectively. In this case, all adjustments will remain stored, the allocated outputs will remain occupied and cannot be allocated to another function. The allocated sensor will be monitored for faults.

By selecting **Switch**, the function can be activated or deactivated respectively by means of an external potential-free switch.

If **Switch** is selected, the channel **Sensor** appears, in which a sensor input can be defined as a switch.

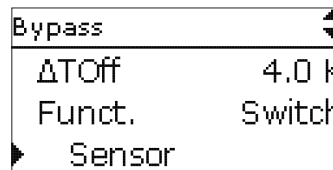

4.6 Output submenu

The **Output** submenu is available in almost all optional functions. Therefore, it will not be explained in the individual function descriptions.

In this submenu, relays and/or signal outputs can be allocated to the function selected. All adjustments required for the outputs can be made in this menu.

All controller and module (if connected) outputs available will be displayed.

Adjustments

| Relay option | PWM/0-10 V option | Speed control | Adapter option |
|--------------|-------------------|---------------|----------------|
| Yes | Yes | Yes | Yes |
| Yes | No | Yes | No |
| Yes | No | Yes | Yes |
| Yes | No | No | irrelevant* |
| Yes | Yes | Yes | No |
| Yes | Yes | Yes | Yes |
| Yes | Yes | No | irrelevant* |
| No | Yes | Yes | irrelevant* |
| No | Yes | No | irrelevant* |

*If the relay option and/or speed control is deactivated, the adjustment in the adapter option will have no effect.

| Adjustment channel | Description | Adjustment range / selection | Factory setting |
|--------------------|----------------------------|------------------------------|------------------|
| Relay | Relay option | Yes, No | No |
| Relay | Relay selection | system dependent | system dependent |
| PWM/0-10 V | PWM/0-10 V option | Yes, No | No |
| Output | Signal output selection | system dependent | system dependent |
| Signal | Signal type | PWM, 0-10 V | PWM |
| Profile | Curve | Solar, Heating | Solar |
| Speed | Speed control | Yes, No | system dependent |
| Min. | Minimum speed | 20 ... 100% | 30% |
| Max. | Maximum speed | 20 ... 100% | 100% |
| Adapter | Adapter option | Yes, No | No |
| Inverted | Inverted switching option | Yes, No | No |
| Blocking protect. | Blocking protection option | Yes, No | No |
| Manual mode | Operating mode | Max., Auto, Min., Off | Auto |

If - is selected, the function will run normally in the software but will not operate an output. Relay and signal outputs can be activated separately. Depending on the adjustments made, the following results are possible:

Result

| Behaviour of the relay output | Behaviour of the signal output | Behaviour of the adapter |
|-------------------------------|--------------------------------|--------------------------|
| → On/Off | Modulating | Modulating |
| → Burst control | - | Modulating |
| → On/Off | - | Modulating |
| → On/Off | - | 0% / 100% |
| → On/Off | Modulating | 0% / 100% |
| → On/Off | Modulating | Modulating |
| → On/Off | 0% / 100% | 0% / 100% |
| → - | Modulating | - |
| → - | 0% / 100% | - |

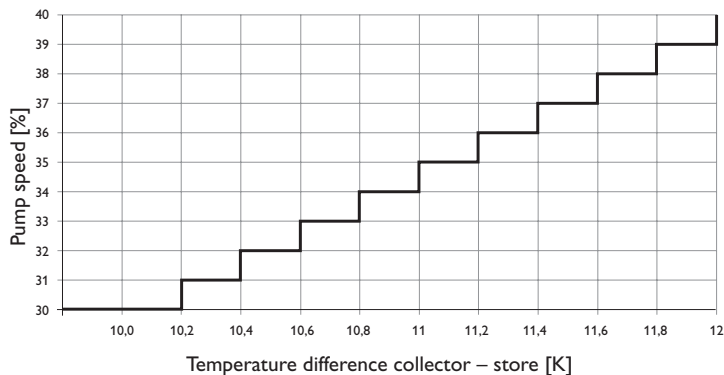
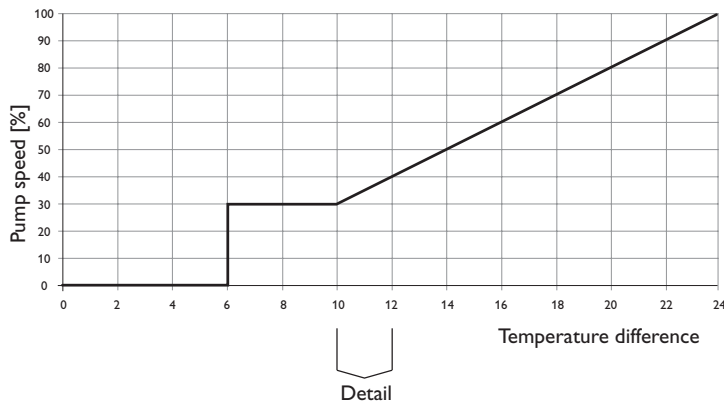

Speed control

In the **Speed** adjustment channel, the speed control for the output can be activated or deactivated respectively. If **Yes** is selected, the channels **Min.**, **Max.** and **Adapter** will appear.

In the **Min.** adjustment channel, a relative minimum speed for a pump connected can be allocated to the output

In the **Max.** adjustment channel, a relative maximum speed for a pump connected can be allocated to the output.

If the speed control signal is generated via a VBus®/PWM interface adapter, the **Adapter** option has to be activated. If **Yes** is selected, the relay will switch on or off (no burst control). Speed information will be transmitted via the VBus®.

For functions controlling loads which are not speed controlled, the speed control will not be shown on the display (e.g. the bypass type, mixer).

If the temperature difference reaches or exceeds the switch-on temperature difference, the pump switches on at 100% speed for 10 s. Then, the speed is reduced to the minimum pump speed value. If the temperature difference exceeds the adjusted set value by 1/10 of the rise value, the pump speed increases by one step (1%). The response of the controller can be adapted via the parameter **Rise**. Each time the difference increases by 1/10 of the adjustable rise value, the pump speed increases by one step until the maximum pump speed of 100% is reached. If the temperature difference decreases by 1/10 of the adjustable rise value, pump speed will be decreased by one step.

Relay option

If the **Relay** option is activated, a relay can be allocated to the output selection.

PWM/0-10 V option

If the **PWM/0-10 V** option is activated, a PWM/0-10 V output can be allocated to the output selection.

In the **Signal** channel, a selection between a PWM or a 0-10 V signal can be made. In the **Profile** channel, characteristic curves for solar and heating pumps can be selected.

Signal characteristic: PWM; Profile: Solar

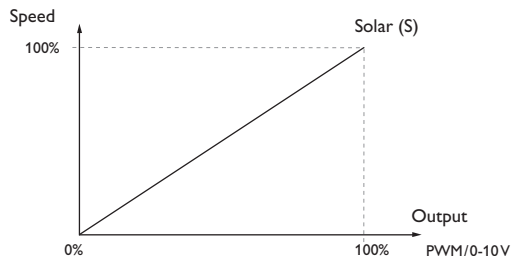

Signal characteristic: PWM; Profile: Heating

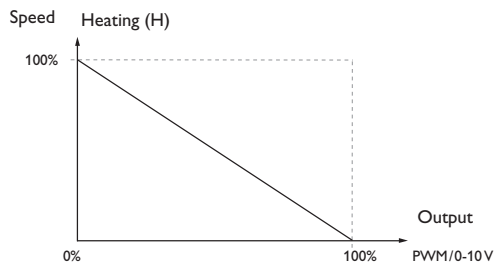

Blocking protection

In order to protect the pumps against blocking after standstill, the controller is equipped with a blocking protection option. This option can be activated in the output selection submenu. The **Blocking protection** option can be adjusted in the **Basic settings/Blocking protect.** menu (see page 89).

Manual mode

In the **Manual mode** adjustment channel, the operating mode of the output can be selected. The following options are available:

Off = Output is switched off (manual mode)

Min. = Output is active at minimum speed (manual mode)

Max. = Output is active at 100% (manual mode)

Auto = Output is in automatic mode



Note

After service and maintenance work, the operating mode must be set back to Auto. In manual mode the control logic is overridden.

4.7 Sensor configuration

Some sensors must be registered and configured in the **Inputs/Modules** menu (see page 9 and page 91).

In some functions, the **Sensor config.** channel is available for sensor selection, in which sensors not used and not registered can be selected. The selected sensor input will automatically be set to the sensor type required for the function. Registering the sensor in the **Inputs/Modules** menu is then no longer necessary.



Note

If a sensor is used as the temperature sensor of a function, the sensor types **Switch, Fern, BAS, Impulse** and **none** will not be available for the corresponding input.

5 Commissioning

When the hydraulic system is filled and ready for operation, connect the controller to the mains.

The controller runs an initialisation phase in which the directional pad glows red. When the controller is commissioned or when it is reset, it will run a commissioning menu after the initialisation phase. The commissioning menu leads the user through the most important adjustment channels needed for operating the system.

Commissioning menu

The commissioning menu consists of the channels described in the following. In order to make an adjustment, press button **5**. Adjust the value by pressing buttons **4** and **2**, then push button **5** to confirm. The next channel will appear in the display.

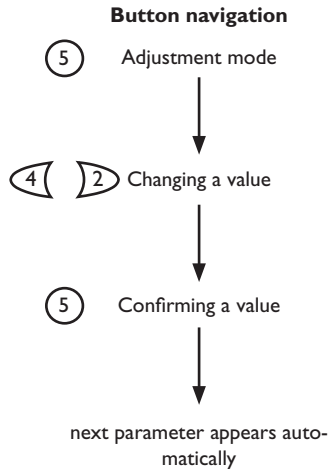

1. Language:

→ Adjust the desired menu language.

| |
|-----------|
| Language |
| Deutsch |
| ▶ English |
| Francais |

2. Units:

→ Adjust the desired unit system.

| |
|---|
| Units |
| <input type="radio"/> °F / gal / MBTU |
| ▶ <input checked="" type="radio"/> °C / Liter / kWh |

3. Daylight savings time adjustment:

→ Activate or deactivate the automatic daylight savings time adjustment.

| |
|--|
| Auto DST |
| ▶ <input checked="" type="radio"/> Yes |
| <input type="radio"/> No |

4. Time:

→ Adjust the clock time. First of all adjust the hours, then the minutes.

| |
|-------|
| Time |
| 12:26 |

5. Date:

→ Adjust the date. First of all adjust the year, then the month and then the day.

| |
|------------|
| Date |
| ?? ?? 2016 |

6. Selection: System or Scheme

→ Choose whether the controller is to be configured with a scheme number or with a system and a variant.

| |
|---|
| System or scheme |
| <input type="radio"/> Scheme |
| ▶ <input checked="" type="radio"/> System |

7a. Scheme (if 6. = Scheme):

- ➔ Enter the scheme number of the desired system.

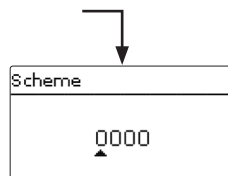

7b. Selection of the solar system (if 6. = System):

- ➔ Adjust the desired solar system (number of collectors and stores, hydraulic variants).

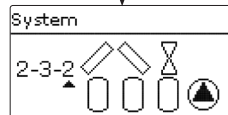

8. Completing the commissioning menu:

After the system has been selected or the scheme number has been entered, a security enquiry appears. If the security enquiry is confirmed, the adjustments will be saved.

- ➔ In order to confirm the security enquiry, press button (5).
- ➔ In order to reenter the commissioning menu channels, press button (7). If the security enquiry has been confirmed, the controller will be ready for operation.

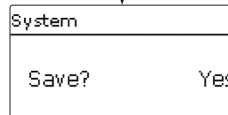

Note

The adjustments carried out during commissioning can be changed anytime in the corresponding adjustment channel. Additional functions and options can also be activated and adjusted (see page 44).

Set the code to the customer code before handing over the controller to the customer (see page 91).

5.1 Basic systems

The controller is pre-programmed for different basic systems. The selection depends on the number of heat sources (collector fields) and heat sinks (stores, pool). The selection of the basic solar system is one of the most important adjustments and is thus requested already in the commissioning menu.

First, the number of collector fields and stores will have to be adjusted, then the hydraulic variant.



Note

A solar system with store loading in layers is implemented as a 2-store system (store top = store 1; store base = store 2).

The system selected is visualised by the corresponding number of store and collector symbols. The exemplary figure shows system 2.3.x with 2 collector fields and 2 stores.

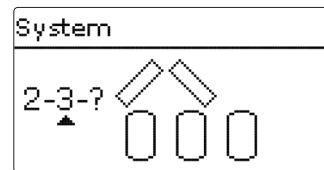

The hydraulic variant refers to the different actuators that are to be controlled. They are visualised on the display by means of symbols, when the variant is selected. The upper symbol indicates the actuator belonging to the collector fields, the lower one the actuators belonging to the stores.

The exemplary figure shows the display indicated when system 2.3.2 has been selected.

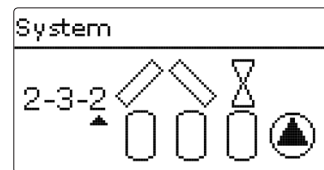

In this case, each collector field has a 2-port valve, the stores are loaded by means of pump logic.

The controller allocates corresponding output and sensor settings for each basic system. The allocations of all combinations are shown in chap. 5.2.

System 1.1.1

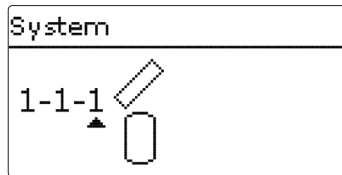

| Sensors | | Relays; PWM/0-10 | |
|-------------|----|------------------|------|
| Collector 1 | S1 | Solar pump | R1;A |
| Store base | S2 | | |

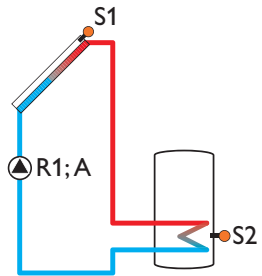

System 1.2.1

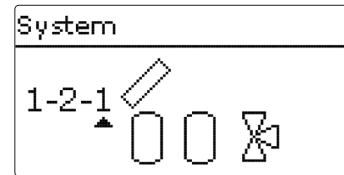

| Sensors | | Relays; PWM/0-10 | |
|--------------|----|------------------|------|
| Collector | S1 | Solar pump | R1;A |
| Store 1 base | S2 | 3-PV store 2 | R2 |
| Store 2 base | S4 | | |

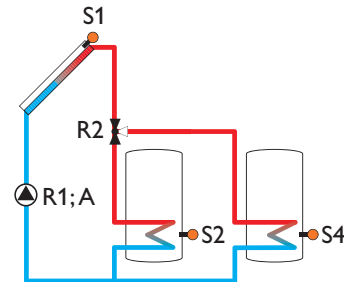

System 1.2.2

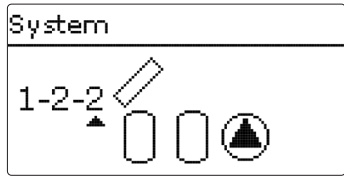

| Sensors | | Relays; PWM/0-10 | |
|--------------|----|--------------------|-------|
| Collector | S1 | Solar pump store 1 | R1; A |
| Store 1 base | S2 | Solar pump store 2 | R2; B |
| Store 2 base | S4 | | |

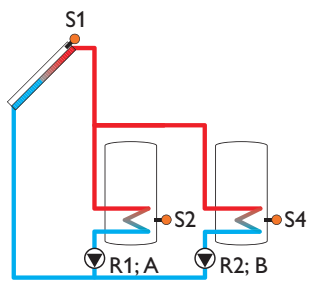

System 1.2.3

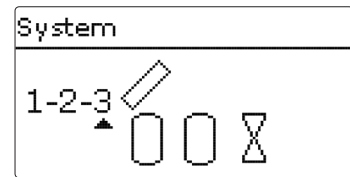

| Sensors | | Relays; PWM/0-10 | |
|--------------|----|------------------|-------|
| Collector | S1 | Solar pump | R1; A |
| Store 1 base | S2 | 2-PV store 1 | R2 |
| Store 2 base | S4 | 2-PV store 2 | R3 |

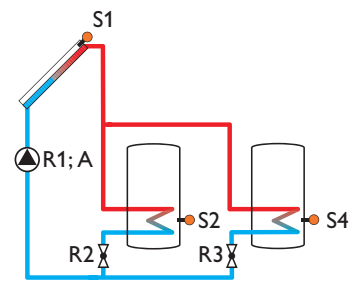

System 1.3.1

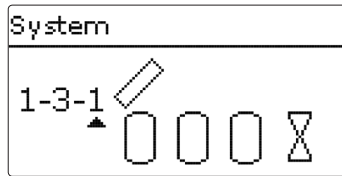

| Sensors | | Relays; PWM/0-10 | |
|--------------|----|------------------|------|
| Collector 1 | S1 | Solar pump | R1;A |
| Store 1 base | S2 | 2-PV store 1 | R2 |
| Store 2 base | S4 | 2-PV store 2 | R3 |
| Store 3 base | S5 | 2-PV store 3 | R4 |

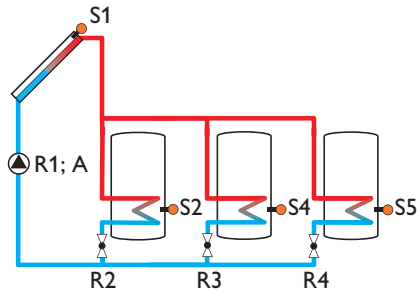

System 1.3.2

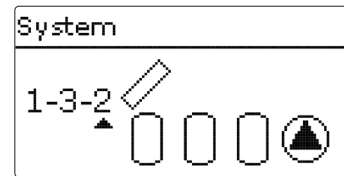

| Sensors | | Relays; PWM/0-10 | |
|--------------|----|--------------------|------|
| Collector 1 | S1 | Solar pump store 1 | R1;A |
| Store 1 base | S2 | Solar pump store 2 | R2;B |
| Store 2 base | S4 | Solar pump store 3 | R3;C |
| Store 3 base | S5 | | |

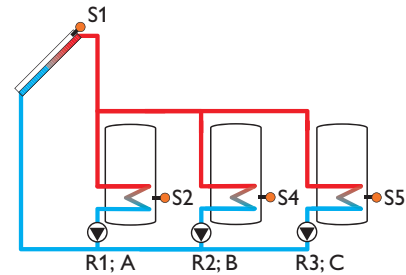

System 1.3.3

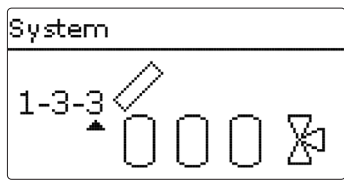

| Sensors | | Relays; PWM/0-10 | |
|--------------|----|------------------|------|
| Collector 1 | S1 | Solar pump | R1;A |
| Store 1 base | S2 | 3-PV store 1 | R2 |
| Store 2 base | S4 | 3-PV store 2 | R3 |
| Store 3 base | S5 | | |

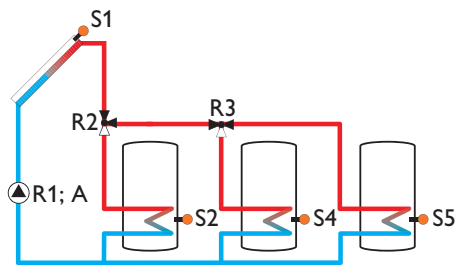

System 1.4.1

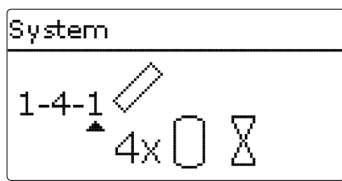

| Sensors | | Relays; PWM/0-10 | |
|--------------|----|------------------|------|
| Collector 1 | S1 | Solar pump | R1;A |
| Store 1 base | S2 | 2-PV store 1 | R2 |
| Store 2 base | S4 | 2-PV store 2 | R3 |
| Store 3 base | S5 | 2-PV store 3 | R4 |
| Store 4 base | S6 | 2-PV store 4 | R5 |

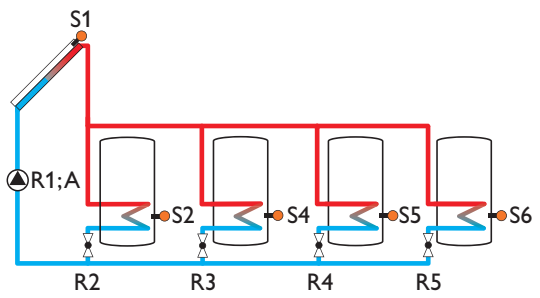

System 1.4.2

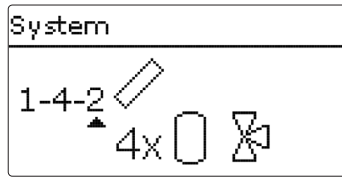

| Sensors | | Relays; PWM/0-10 | |
|--------------|----|------------------|-------|
| Collector 1 | S1 | Solar pump | R1; A |
| Store 1 base | S2 | 3-PV store 1 | R2 |
| Store 2 base | S4 | 3-PV store 2 | R3 |
| Store 3 base | S5 | 3-PV store 3 | R4 |
| Store 4 base | S6 | | |

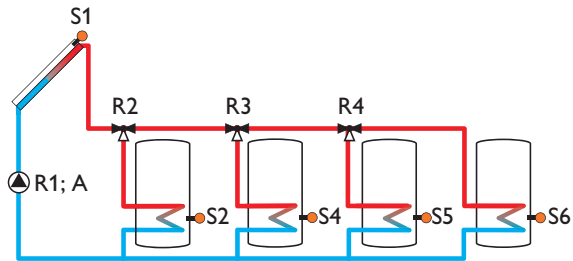

System 1.4.3

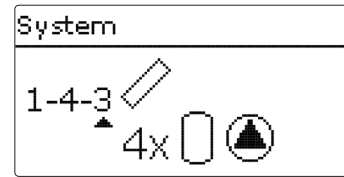

| Sensors | | Relays; PWM/0-10 | |
|--------------|----|--------------------|-------|
| Collector 1 | S1 | Solar pump store 1 | R1; A |
| Store 1 base | S2 | Solar pump store 2 | R2; B |
| Store 2 base | S4 | Solar pump store 3 | R3; C |
| Store 3 base | S5 | Solar pump store 4 | R4; D |
| Store 4 base | S6 | | |

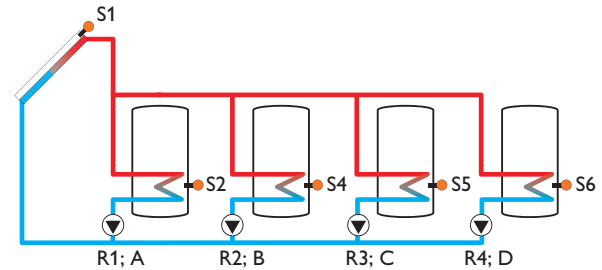

System 1.5.1

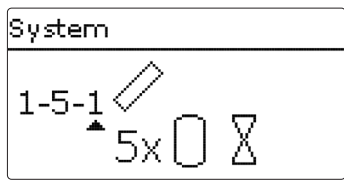

| Sensors | | Relays; PWM/0-10 | |
|--------------|----|------------------|------|
| Collector 1 | S1 | Solar pump | R1;A |
| Store 1 base | S2 | 2-PV store 1 | R2 |
| Store 2 base | S4 | 2-PV store 2 | R3 |
| Store 3 base | S5 | 2-PV store 3 | R4 |
| Store 4 base | S6 | 2-PV store 4 | R5 |
| Store 5 base | S7 | 2-PV store 5 | R6 |

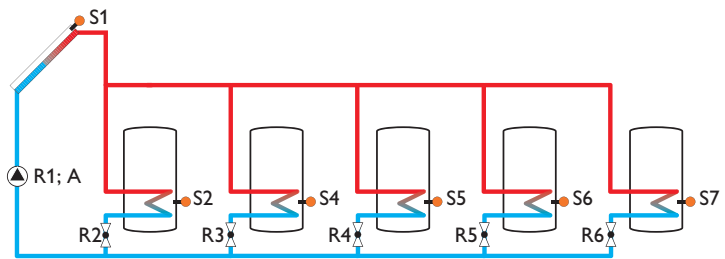

System 1.5.2

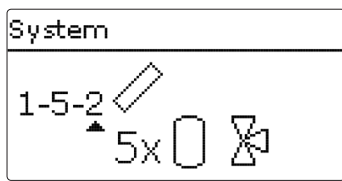

| Sensors | | Relays; PWM/0-10 | |
|--------------|----|------------------|------|
| Collector 1 | S1 | Solar pump | R1;A |
| Store 1 base | S2 | 3-PV store 1 | R2 |
| Store 2 base | S4 | 3-PV store 2 | R3 |
| Store 3 base | S5 | 3-PV store 3 | R4 |
| Store 4 base | S6 | 3-PV store 4 | R5 |
| Store 5 base | S7 | | |

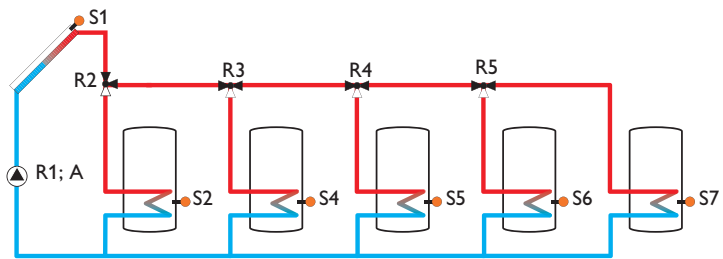

System 1.5.3

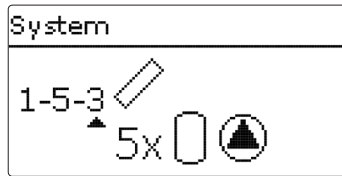

| Sensors | | Relays; PWM/0-10 | |
|--------------|----|--------------------|------------|
| Collector 1 | S1 | Solar pump store 1 | R1; A |
| Store 1 base | S2 | Solar pump store 2 | R2; B |
| Store 2 base | S4 | Solar pump store 3 | R3; C |
| Store 3 base | S5 | Solar pump store 4 | R4; D |
| Store 4 base | S6 | Solar pump store 5 | R5; on/off |
| Store 5 base | S7 | | |

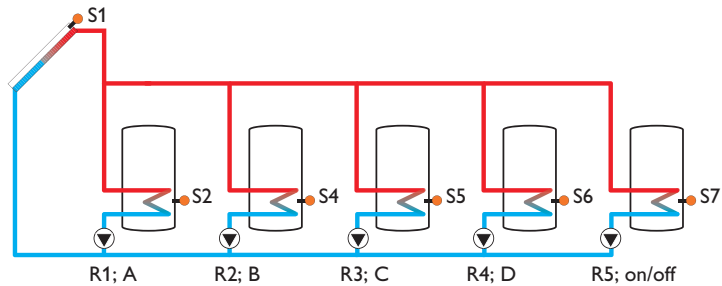

System 2.1.1

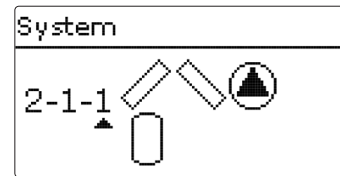

| Sensors | | Relays; PWM/0-10 | |
|-------------|----|------------------|-------|
| Collector 1 | S1 | Pump collector 1 | R1; A |
| Store base | S2 | Pump collector 2 | R2; B |
| Collector 2 | S6 | | |

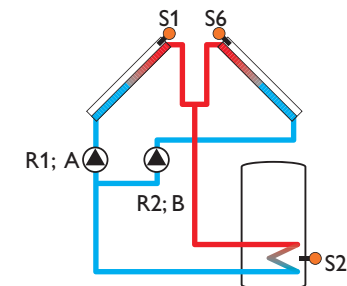

System 2.1.2

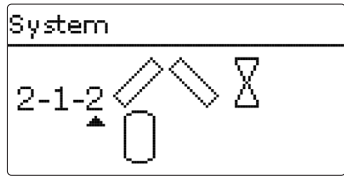

| Sensors | | Relays; PWM/0-10 | |
|-------------|----|------------------|------|
| Collector 1 | S1 | 2-PV collector 1 | R1 |
| Store base | S2 | 2-PV collector 2 | R2 |
| Collector 2 | S6 | Solar pump | R3;A |

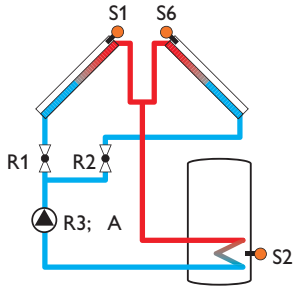

System 2.2.1

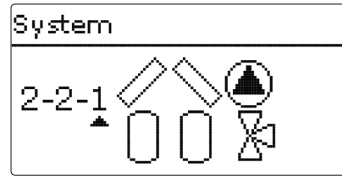

| Sensors | | Relays; PWM/0-10 | |
|--------------|----|------------------|-------|
| Collector 1 | S1 | Pump collector 1 | R1;A |
| Store 1 base | S2 | Pump collector 2 | R2; B |
| Store 2 base | S4 | 3-PV store 2 | R3 |
| Collector 2 | S6 | | |

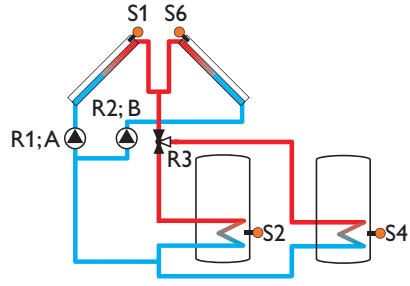

System 2.2.2

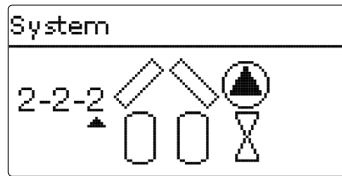

| Sensors | | Relays; PWM/0-10 | |
|--------------|----|------------------|------|
| Collector 1 | S1 | Pump collector 1 | R1;A |
| Store 1 base | S2 | Pump collector 2 | R2;B |
| Store 2 base | S4 | 2-PV store 1 | R3 |
| Collector 2 | S6 | 2-PV store 2 | R4 |

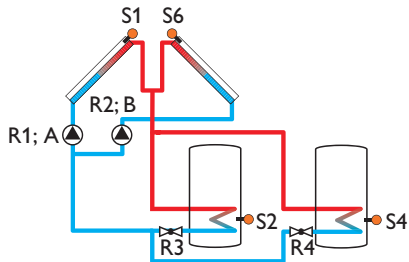

System 2.2.3

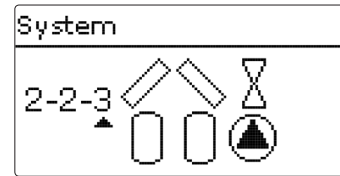

| Sensors | | Relays; PWM/0-10 | |
|--------------|----|--------------------|------|
| Collector 1 | S1 | 2-PV collector 1 | R1 |
| Store 1 base | S2 | 2-PV collector 2 | R2 |
| Store 2 base | S4 | Solar pump store 1 | R3;A |
| Collector 2 | S6 | Solar pump store 2 | R4;B |

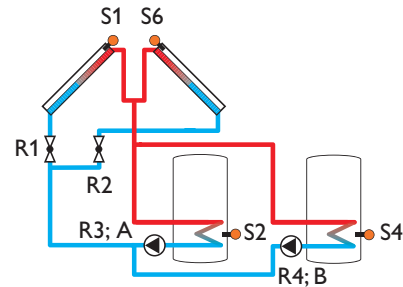

System 2.2.4

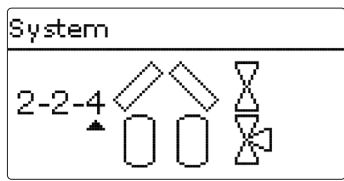

| Sensors | | Relays; PWM/0-10 | |
|--------------|----|------------------|------|
| Collector 1 | S1 | 2-PV collector 1 | R1 |
| Store 1 base | S2 | 2-PV collector 2 | R2 |
| Store 2 base | S4 | Solar pump | R3;A |
| Collector 2 | S6 | 3-PV store 2 | R4 |

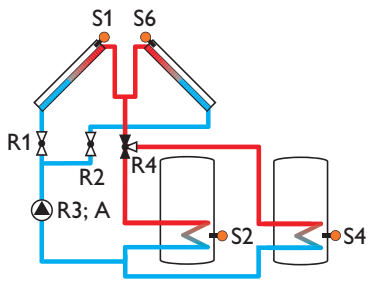

System 2.2.5

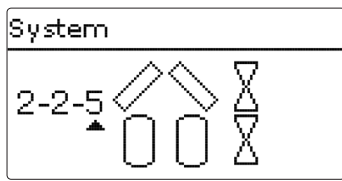

| Sensors | | Relays; PWM/0-10 | |
|--------------|----|------------------|------|
| Collector 1 | S1 | 2-PV collector 1 | R1 |
| Store 1 base | S2 | 2-PV collector 2 | R2 |
| Store 2 base | S4 | Solar pump | R3;A |
| Collector 2 | S6 | 2-PV store 1 | R4 |
| | | 2-PV store 2 | R5 |

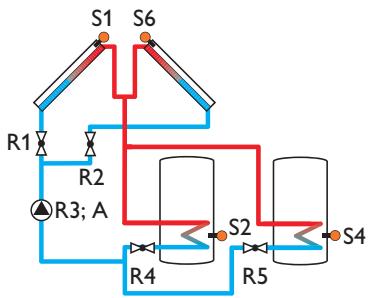

System 2.3.1

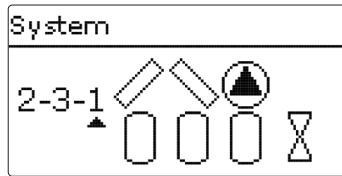

| Sensors | | Relays; PWM/0-10 | |
|--------------|----|------------------|------|
| Collector 1 | S1 | Pump collector 1 | R1;A |
| Store 1 base | S2 | Pump collector 2 | R2;B |
| Store 2 base | S4 | 2-PV store 1 | R3 |
| Store 3 base | S5 | 2-PV store 2 | R4 |
| Collector 2 | S6 | 2-PV store 3 | R5 |

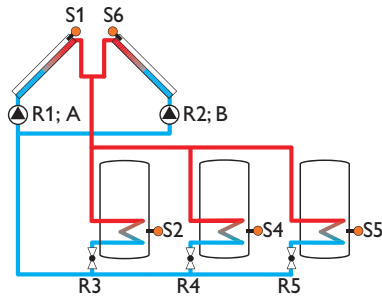

System 2.3.2

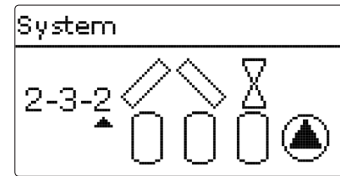

| Sensors | | Relays; PWM/0-10 | |
|--------------|----|--------------------|------|
| Collector 1 | S1 | Solar pump store 1 | R1;A |
| Store 1 base | S2 | Solar pump store 2 | R2;B |
| Store 2 base | S4 | Solar pump store 3 | R3;C |
| Store 3 base | S5 | 2-PV collector 1 | R4 |
| Collector 2 | S6 | 2-PV collector 2 | R5 |

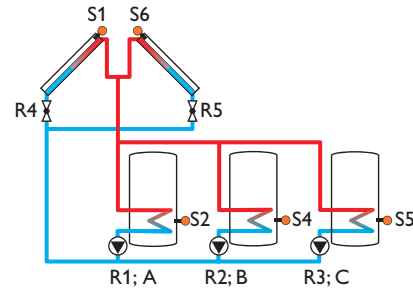

System 2.3.3

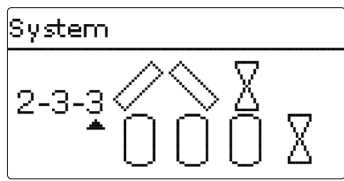

| Sensors | | Relays; PWM/0-10 | |
|--------------|----|------------------|------|
| Collector 1 | S1 | 2-PV collector 1 | R1 |
| Store 1 base | S2 | 2-PV collector 2 | R2 |
| Store 2 base | S4 | Solar pump | R3;A |
| Store 3 base | S5 | 2-PV store 1 | R4 |
| Collector 2 | S6 | 2-PV store 2 | R5 |
| | | 2-PV store 3 | R6 |

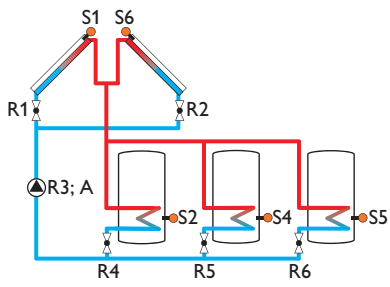

System 2.3.4

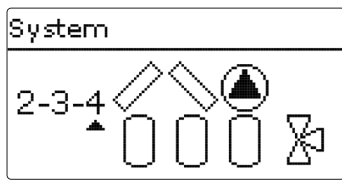

| Sensors | | Relays; PWM/0-10 | |
|--------------|----|------------------|-------|
| Collector 1 | S1 | Pump collector 1 | R1;A |
| Store 1 base | S2 | Pump collector 2 | R2; B |
| Store 2 base | S4 | 3-PV store 1 | R3 |
| Store 3 base | S5 | 3-PV store 2 | R4 |
| Collector 2 | S6 | | |

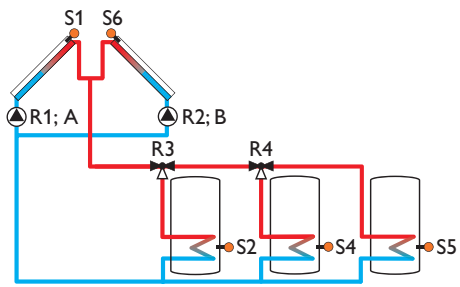

System 2.3.5

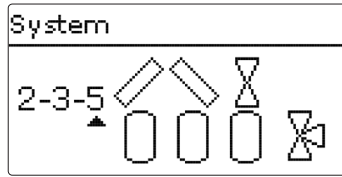

| Sensors | | Relays; PWM/0-10 | |
|--------------|----|------------------|------|
| Collector 1 | S1 | 2-PV collector 1 | R1 |
| Store 1 base | S2 | 2-PV collector 2 | R2 |
| Store 2 base | S4 | Solar pump | R3;A |
| Store 3 base | S5 | 3-PV store 1 | R4 |
| Collector 2 | S6 | 3-PV store 2 | R5 |

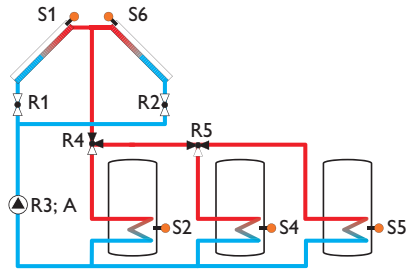

System 2.4.1

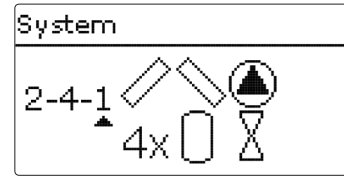

| Sensors | | Relays; PWM/0-10 | |
|--------------|----|------------------|------|
| Collector 1 | S1 | Pump collector 1 | R1;A |
| Store 1 base | S2 | Pump collector 2 | R2;B |
| Store 2 base | S4 | 2-PV store 1 | R3 |
| Store 3 base | S5 | 2-PV store 2 | R4 |
| Collector 2 | S6 | 2-PV store 3 | R5 |
| Store 4 base | S7 | 2-PV store 4 | R6 |

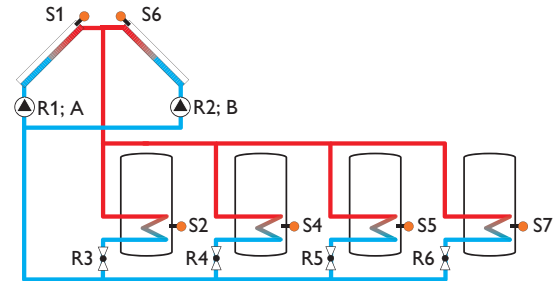

System 2.4.2

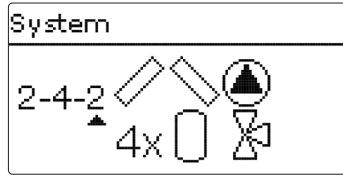

Sensors

| | |
|--------------|----|
| Collector 1 | S1 |
| Store 1 base | S2 |
| Store 2 base | S4 |
| Store 3 base | S5 |
| Collector 2 | S6 |
| Store 4 base | S7 |

Relays; PWM/0-10

| | |
|------------------|-------|
| Pump collector 1 | R1; A |
| Pump collector 2 | R2; B |
| 3-PV store 1 | R3 |
| 3-PV store 2 | R4 |
| 3-PV store 3 | R5 |

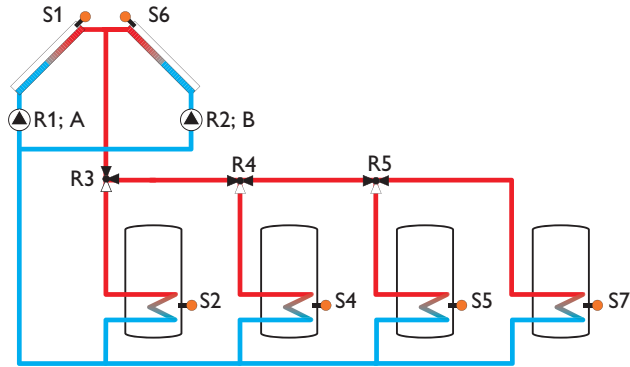

System 2.4.3

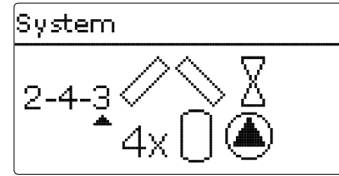

Sensors

| | |
|--------------|----|
| Collector 1 | S1 |
| Store 1 base | S2 |
| Store 2 base | S4 |
| Store 3 base | S5 |
| Collector 2 | S6 |
| Store 4 base | S7 |

Relays; PWM/0-10

| | |
|--------------------|-------|
| Solar pump store 1 | R1; A |
| Solar pump store 2 | R2; B |
| Solar pump store 3 | R3; C |
| Solar pump store 4 | R4; D |
| 2-PV collector 1 | R5 |
| 2-PV collector 2 | R6 |

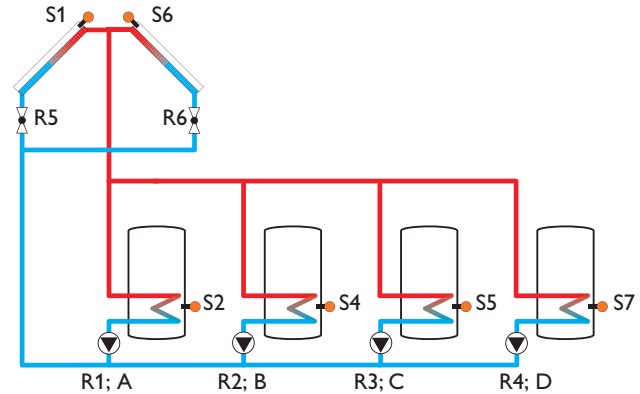

System 2.4.4

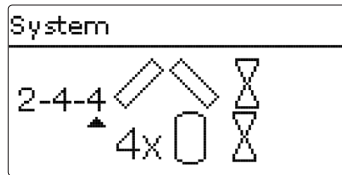

| Sensors | | Relays; PWM/0-10 | |
|--------------|----|------------------|------|
| Collector 1 | S1 | 2-PV collector 1 | R1 |
| Store 1 base | S2 | 2-PV collector 2 | R2 |
| Store 2 base | S4 | Solar pump | R3;A |
| Store 3 base | S5 | 2-PV store 1 | R4 |
| Collector 2 | S6 | 2-PV store 2 | R5 |
| Store 4 base | S7 | 2-PV store 3 | R6 |
| | | 2-PV store 4 | R7 |

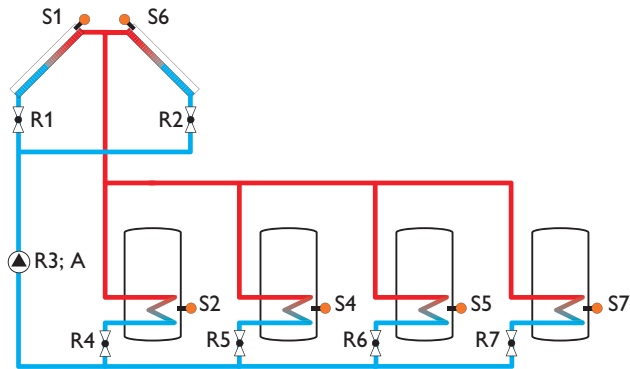

System 2.4.5

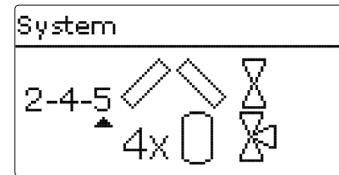

| Sensors | | Relays; PWM/0-10 | |
|--------------|----|------------------|------|
| Collector 1 | S1 | 2-PV collector 1 | R1 |
| Store 1 base | S2 | 2-PV collector 2 | R2 |
| Store 2 base | S4 | Solar pump | R3;A |
| Store 3 base | S5 | 3-PV store 1 | R4 |
| Collector 2 | S6 | 3-PV store 2 | R5 |
| Store 4 base | S7 | 3-PV store 3 | R6 |

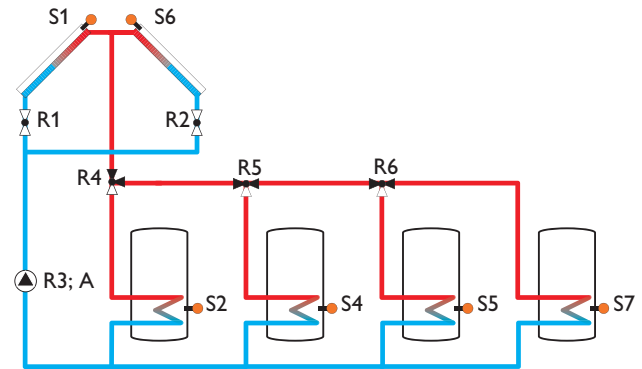

System 3.1.1

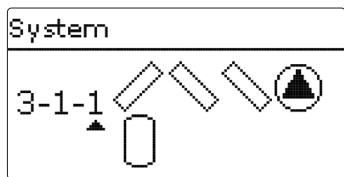

Sensors

| | |
|-------------|----|
| Collector 1 | S1 |
| Store base | S2 |
| Collector 2 | S6 |
| Collector 3 | S8 |

Relays; PWM/0-10

| | |
|------------------|-------|
| Pump collector 1 | R1; A |
| Pump collector 2 | R2; B |
| Pump collector 3 | R3; C |

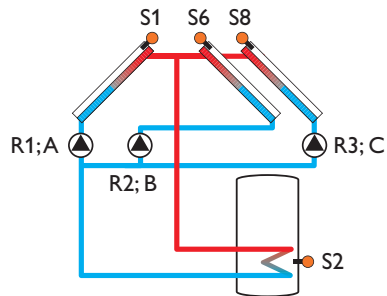

System 3.1.2

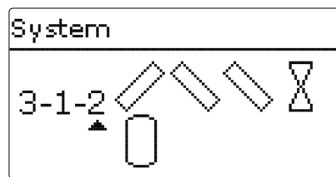

Sensors

| | |
|-------------|----|
| Collector 1 | S1 |
| Store base | S2 |
| Collector 2 | S6 |
| Collector 3 | S8 |

Relays; PWM/0-10

| | |
|------------------|-------|
| 2-PV collector 1 | R1 |
| 2-PV collector 2 | R2 |
| Solar pump | R3; A |
| 2-PV collector 3 | R4 |

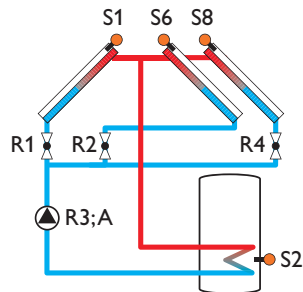

System 3.2.1

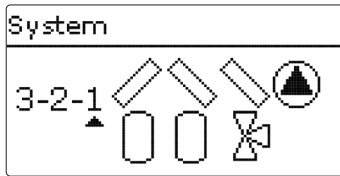

| Sensors | | Relays; PWM/0-10 | |
|--------------|----|------------------|------|
| Collector 1 | S1 | Pump collector 1 | R1;A |
| Store 1 base | S2 | Pump collector 2 | R2;B |
| Store 2 base | S4 | 3-PV store 2 | R3 |
| Collector 2 | S6 | Pump collector 3 | R4;C |
| Collector 3 | S8 | | |

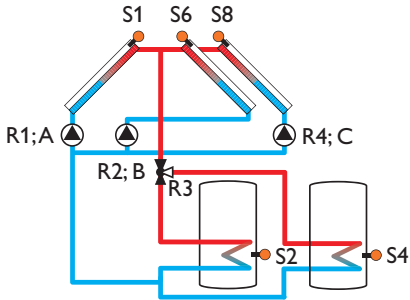

System 3.2.2

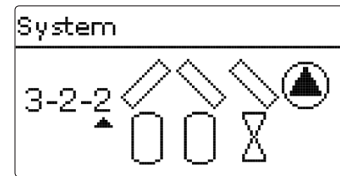

| Sensors | | Relays; PWM/0-10 | |
|--------------|----|------------------|------|
| Collector 1 | S1 | Pump collector 1 | R1;A |
| Store 1 base | S2 | Pump collector 2 | R2;B |
| Store 2 base | S4 | 2-PV store 1 | R3 |
| Collector 2 | S6 | 2-PV store 2 | R4 |
| Collector 3 | S8 | Pump collector 3 | R5;C |

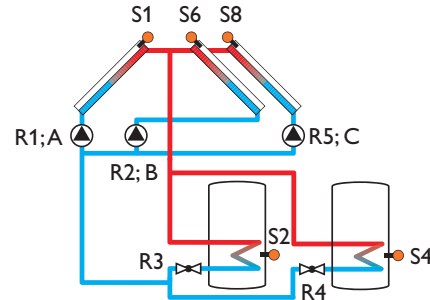

System 3.2.3

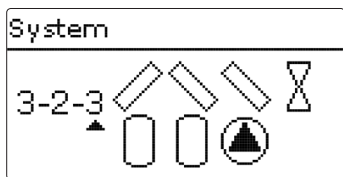

| Sensors | | Relays; PWM/0-10 | |
|--------------|----|--------------------|------|
| Collector 1 | S1 | 2-PV collector 1 | R1 |
| Store 1 base | S2 | 2-PV collector 2 | R2 |
| Store 2 base | S4 | Solar pump store 1 | R3;A |
| Collector 2 | S6 | Solar pump store 2 | R4;B |
| Collector 3 | S8 | 2-PV collector 3 | R5 |

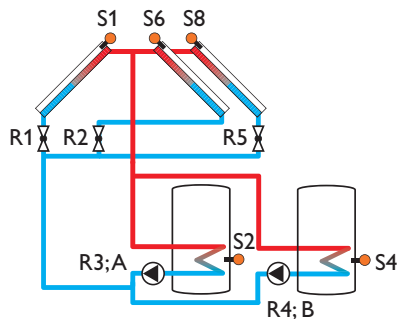

System 3.2.4

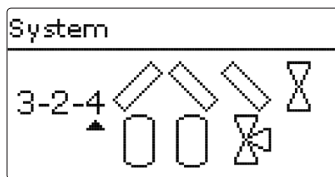

| Sensors | | Relays; PWM/0-10 | |
|--------------|----|------------------|------|
| Collector 1 | S1 | 2-PV collector 1 | R1 |
| Store 1 base | S2 | 2-PV collector 2 | R2 |
| Store 2 base | S4 | Solar pump | R3;A |
| Collector 2 | S6 | 3-PV store 2 | R4 |
| Collector 3 | S8 | 2-PV collector 3 | R5 |

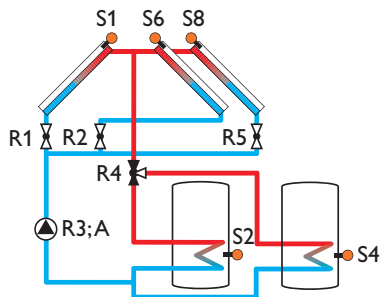

System 3.2.5

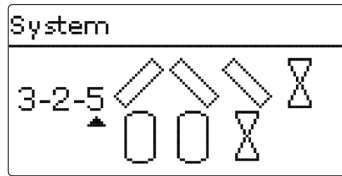

| Sensors | | Relays; PWM/0-10 | |
|--------------|----|------------------|------|
| Collector 1 | S1 | 2-PV collector 1 | R1 |
| Store 1 base | S2 | 2-PV collector 2 | R2 |
| Store 2 base | S4 | Solar pump | R3;A |
| Collector 2 | S6 | 2-PV store 1 | R4 |
| Collector 3 | S8 | 2-PV store 2 | R5 |
| | | 2-PV collector 3 | R6 |

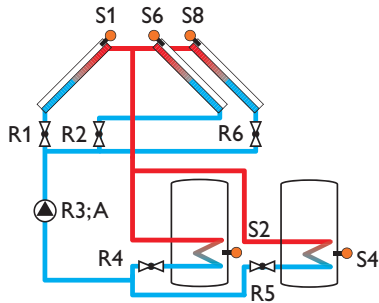

System 3.3.1

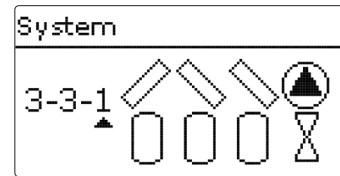

| Sensors | | Relays; PWM/0-10 | |
|--------------|----|------------------|------|
| Collector 1 | S1 | Pump collector 1 | R1;A |
| Store 1 base | S2 | Pump collector 2 | R2;B |
| Store 2 base | S4 | 2-PV store 1 | R3 |
| Store 3 base | S5 | 2-PV store 2 | R4 |
| Collector 2 | S6 | 2-PV store 3 | R5 |
| Collector 3 | S8 | Pump collector 3 | R6;C |

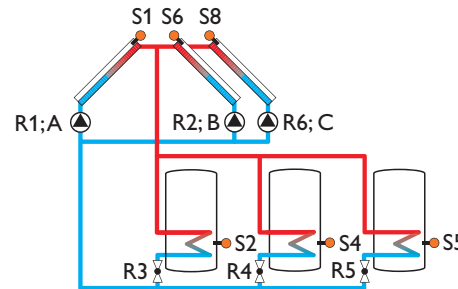

System 3.3.2

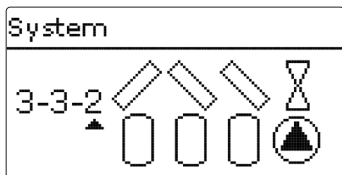

Sensors

| | |
|--------------|----|
| Collector 1 | S1 |
| Store 1 base | S2 |
| Store 2 base | S4 |
| Store 3 base | S5 |
| Collector 2 | S6 |
| Collector 3 | S8 |

Relays; PWM/0-10

| | |
|--------------------|------|
| Solar pump store 1 | R1;A |
| Solar pump store 2 | R2;B |
| Solar pump store 3 | R3;C |
| 2-PV collector 1 | R4 |
| 2-PV collector 2 | R5 |
| 2-PV collector 3 | R6 |

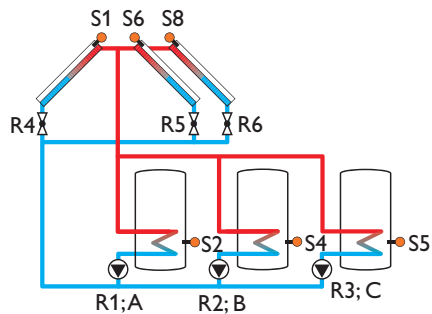

System 3.3.3

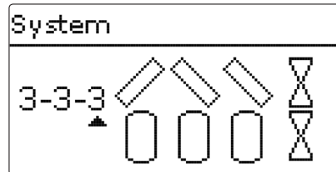

Sensors

| | |
|--------------|----|
| Collector 1 | S1 |
| Store 1 base | S2 |
| Store 2 base | S4 |
| Store 3 base | S5 |
| Collector 2 | S6 |
| Collector 3 | S8 |

Relays; PWM/0-10

| | |
|------------------|------|
| 2-PV collector 1 | R1 |
| 2-PV collector 2 | R2 |
| Solar pump | R3;A |
| 2-PV store 1 | R4 |
| 2-PV store 2 | R5 |
| 2-PV store 3 | R6 |
| 2-PV collector 3 | R7 |

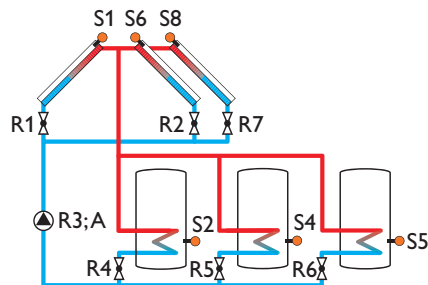

System 3.3.4

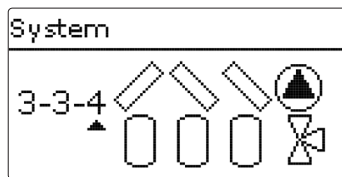

| Sensors | | Relays; PWM/0-10 | |
|--------------|----|------------------|------|
| Collector 1 | S1 | Pump collector 1 | R1;A |
| Store 1 base | S2 | Pump collector 2 | R2;B |
| Store 2 base | S4 | 3-PV store 1 | R3 |
| Store 3 base | S5 | 3-PV store 2 | R4 |
| Collector 2 | S6 | Pump collector 3 | R5;C |
| Collector 3 | S8 | | |

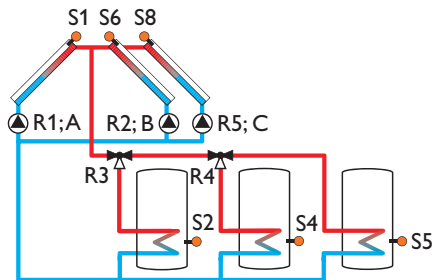

System 3.3.5

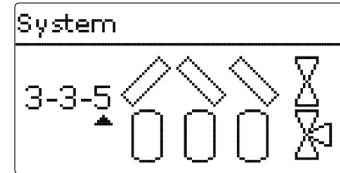

| Sensors | | Relays; PWM/0-10 | |
|--------------|----|------------------|------|
| Collector 1 | S1 | 2-PV collector 1 | R1 |
| Store 1 base | S2 | 2-PV collector 2 | R2 |
| Store 2 base | S4 | Solar pump | R3;A |
| Store 3 base | S5 | 3-PV store 1 | R4 |
| Collector 2 | S6 | 3-PV store 2 | R5 |
| Collector 3 | S8 | 2-PV collector 3 | R6 |

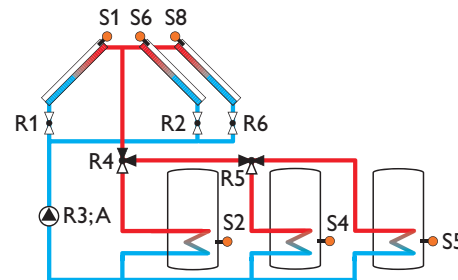

System 3.4.1

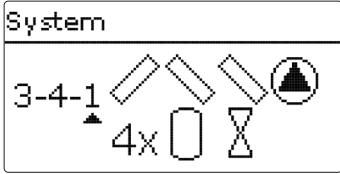

Sensors

| | |
|--------------|----|
| Collector 1 | S1 |
| Store 1 base | S2 |
| Store 2 base | S4 |
| Store 3 base | S5 |
| Collector 2 | S6 |
| Store 4 base | S7 |
| Collector 3 | S8 |

Relays; PWM/0-10

| | |
|------------------|-------|
| Pump collector 1 | R1; A |
| Pump collector 2 | R2; B |
| 2-PV store 1 | R3 |
| 2-PV store 2 | R4 |
| 2-PV store 3 | R5 |
| 2-PV store 4 | R6 |
| Pump collector 3 | R7; C |

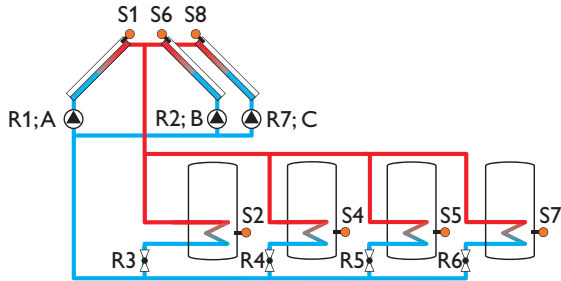

System 3.4.2

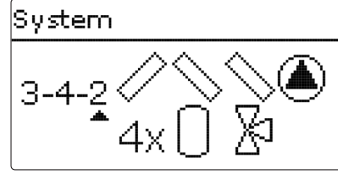

Sensors

| | |
|--------------|----|
| Collector 1 | S1 |
| Store 1 base | S2 |
| Store 2 base | S4 |
| Store 3 base | S5 |
| Collector 2 | S6 |
| Store 4 base | S7 |
| Collector 3 | S8 |

Relays; PWM/0-10

| | |
|------------------|-------|
| Pump collector 1 | R1; A |
| Pump collector 2 | R2; B |
| 3-PV store 1 | R3 |
| 3-PV store 2 | R4 |
| 3-PV store 3 | R5 |
| Pump collector 3 | R6; C |
| Collector 3 | S8 |

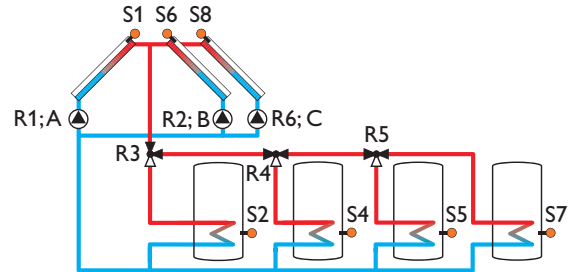

System 3.4.3

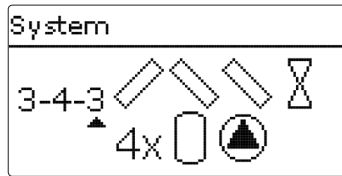

| Sensors | | Relays; PWM/0-10 | |
|--------------|----|--------------------|------|
| Collector 1 | S1 | Solar pump store 1 | R1;A |
| Store 1 base | S2 | Solar pump store 2 | R2;B |
| Store 2 base | S4 | Solar pump store 3 | R3;C |
| Store 3 base | S5 | Solar pump store 4 | R4;D |
| Collector 2 | S6 | 2-PV collector 1 | R5 |
| Store 4 base | S7 | 2-PV collector 2 | R6 |
| Collector 3 | S8 | 2-PV collector 3 | R7 |

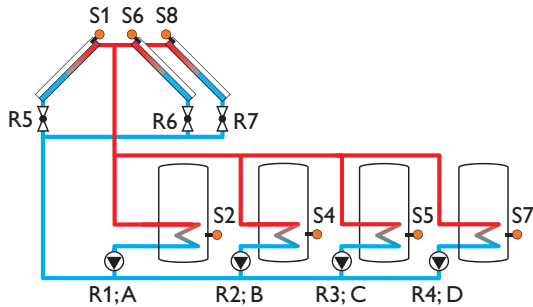

System 3.4.4

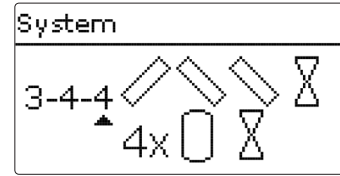

| Sensors | | Relays; PWM/0-10 | |
|--------------|----|------------------|------|
| Collector 1 | S1 | 2-PV collector 1 | R1 |
| Store 1 base | S2 | 2-PV collector 2 | R2 |
| Store 2 base | S4 | Solar pump | R3;A |
| Store 3 base | S5 | 2-PV store 1 | R4 |
| Collector 2 | S6 | 2-PV store 2 | R5 |
| Store 4 base | S7 | 2-PV store 3 | R6 |
| Collector 3 | S8 | 2-PV store 4 | R7 |
| | | 2-PV collector 3 | R8 |

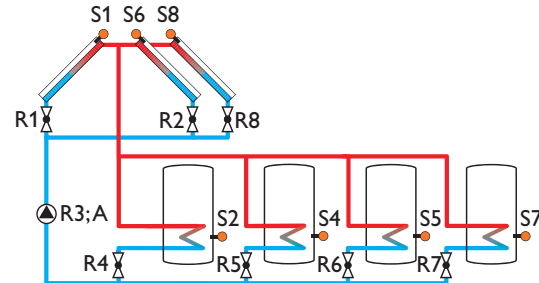

System 3.4.5

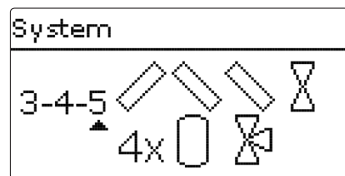

Sensors

| | |
|--------------|----|
| Collector 1 | S1 |
| Store 1 base | S2 |
| Store 2 base | S4 |
| Store 3 base | S5 |
| Collector 2 | S6 |
| Store 4 base | S7 |
| Collector 3 | S8 |

Relays; PWM/0-10

| | |
|------------------|------|
| 2-PV collector 1 | R1 |
| 2-PV collector 2 | R2 |
| Solar pump | R3;A |
| 3-PV store 1 | R4 |
| 3-PV store 2 | R5 |
| 3-PV store 3 | R6 |
| 2-PV collector 3 | R7 |

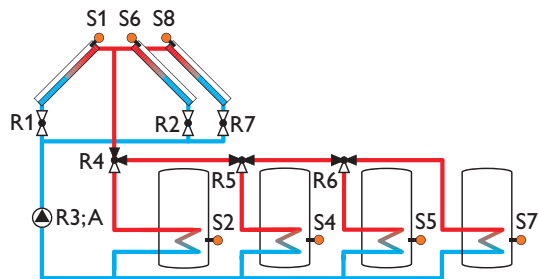

6 Main menu

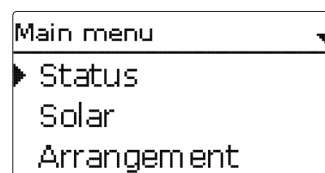

The following menus are available:

- Status
- Solar
- Arrangement
- Heating
- HQM
- Basic settings
- SD card
- Manual mode
- User code
- Inputs/Modules

- ➔ Select the menu area by pressing buttons \uparrow and \downarrow .
- ➔ Press button \circledast in order to enter the menu area selected.



Note

If no button is pressed for 1 min, the display illumination switches off. After 4 further minutes, the controller will display the home screen (see page 47).

- ➔ In order to get from the status menu into the main menu, press button \circledast !

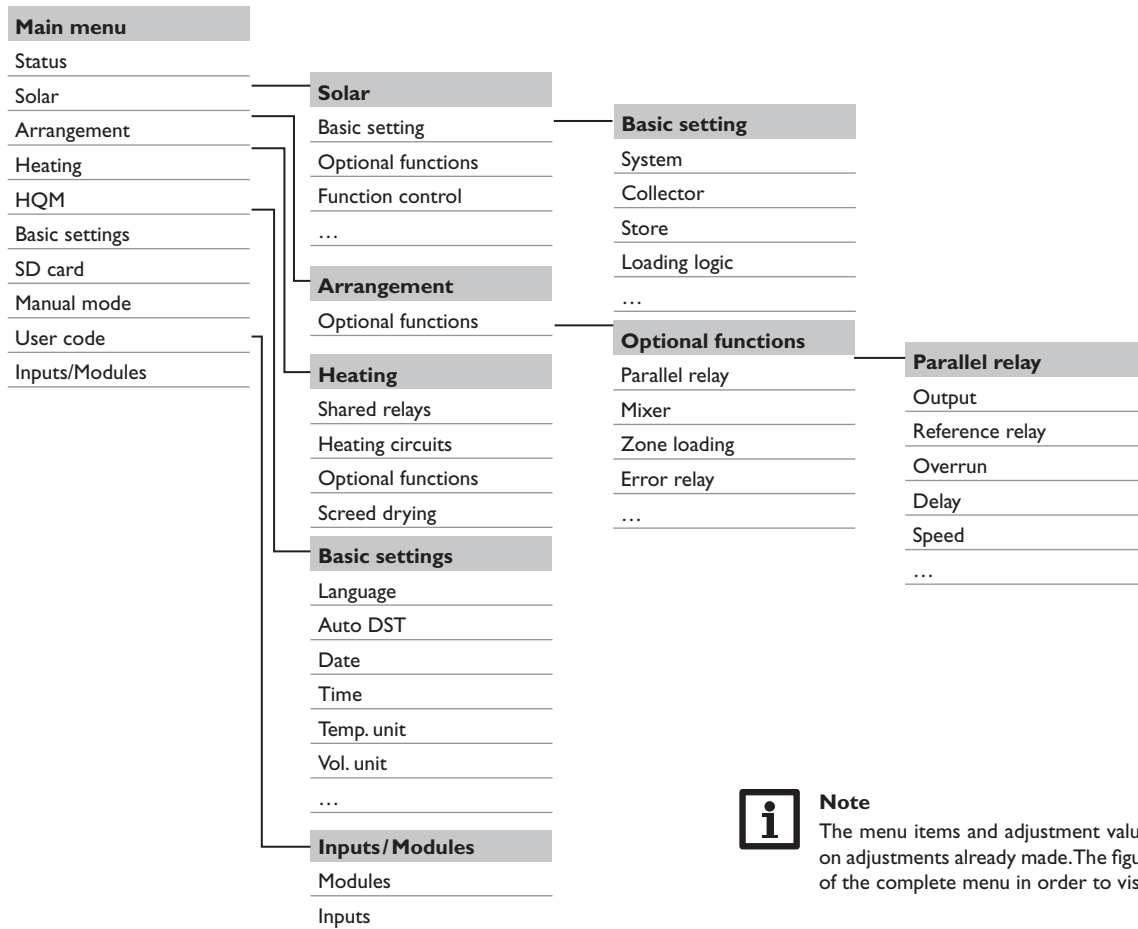
**Note**

The menu items and adjustment values selectable are variable depending on adjustments already made. The figure only shows an exemplary excerpt of the complete menu in order to visualise the menu structure.

7 Status

In the status menu of the controller, the status messages for every menu area can be found.

Use the buttons **2** and **4** for scrolling through the status menu.

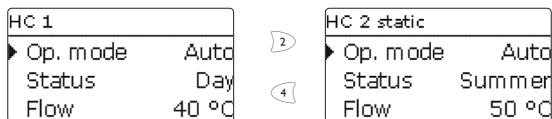

At the end of each submenu, the menu item **Adj. values** can be found.

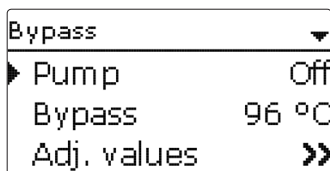

If this one is selected, the corresponding menu opens.

➔ In order to get back to the status menu, press button **7**.

7.1 Measured / Balance values

In the **Status/Meas./Bal. val.** menu, all current measurement values as well as a range of balance values are displayed. Some of the menu items can be selected in order to enter a submenu.

Each sensor and output is indicated with the component or function it has been allocated to. The symbol ▶ at the edge of the display next to a sensor allocated to a function, means that this sensor has several functions. Use buttons **2** and **4** to scroll to these functions. The sensors and outputs of the controller and all modules connected are listed in numerical order.

7.2 Solar

The **Status/Solar** menu shows all status information of the solar system and all optional functions activated.

7.3 Arrangement

The **Status/Arrangement** menu shows all status information of all activated optional functions of the arrangement.

7.4 Heating

In the **Status / Heating** menu, the status of the demands and heating circuits activated as well as of the selected optional functions is indicated.

7.5 HQM

In the **Status / HQM** menu, all current measured values of the flow and return sensors, flow rate and power as well as heat quantities are indicated. Furthermore, all impulse counter values are indicated.

7.6 Messages



In the **Status / Messages** menu, error and warning messages are indicated.

During normal operation, the message **Everything OK** is indicated.

When a monitoring function from the function control is activated and detects a fault condition, a corresponding message will be indicated (see table page 47).

A message consists of the name of the monitoring function, a 4-digit error code and a short text description of the fault condition.

In order to acknowledge a message, proceed as follows:

- ➔ Select the code line of the desired message by pressing buttons **1** and **3**.
- ➔ Acknowledge the message by pressing button **5**.
- ➔ Confirm the security enquiry by selecting **Yes**.

When the installer user code has been entered, the menu item **Restarts** will appear below the messages. The value indicates the number of controller restarts since commissioning. This value cannot be reset.

| Error code | Display | Monitoring function | Cause |
|------------|--------------------|--|---|
| 0001 | !Sensor fault | Sensor line break | Sensor line broken |
| 0002 | !Sensor fault | Sensor short circuit | Sensor line short-circuited |
| 0011 | !ΔT too high | ΔT too high | Collector 50 K > than store to be loaded |
| 0021 | !Night circulation | Night circulation | Betw. 11 pm and 5 am col. temp > 40 °C |
| 0031 | !FL/RE interch. | FL/RL interchanged | Col. temp. does not rise after switching on |
| 0041 | !Flow rate monit. | Flow rate monitoring | No flow at sensor |
| 0051 | !Overpressure | Overpressure monitoring | Max. system pressure exceeded |
| 0052 | !Low pressure | Low pressure monitoring | System pressure below minimum |
| 0061 | !Data storage def. | Storing and changing adjustments not possible | |
| 0071 | !RTC module def. | Time-controlled functions (e.g. night correction) not possible | |
| 0081 | !Store max. temp. | Maximum store temperature | St. max has been exceeded |
| 0091 | Restarts | Restart counter (non-adjustable) | Number of restarts since commissioning |



Note

The **!FL/RE interch.** error can only be correctly detected and indicated, if the collector sensor measures the temperature directly in the fluid at the collector outlet. If the collector sensor is not correctly placed, a false message may occur.

- Place the collector sensor directly in the fluid at the collector outlet or deactivate the **FL/RE interch.** function control.

7.7 Home screen

In the **Home screen** menu, the menu which will appear if no button is pressed for a longer period of time can be selected.

8 Solar

In this menu, all adjustments for the solar part of the arrangement can be made. The **Solar** menu consists of the following submenus:

- Basic setting
- Optional functions
- Function control
- Holiday function
- Expert

8.1 Basic setting

In this menu, all basic settings for the solar part of the arrangement can be adjusted. In this menu, the hydraulic system, which is the basis for the arrangement, can be adjusted. The setting is divided into number of collector fields and stores as well as hydraulic variant.

The number of collector fields and stores as well as the hydraulic variant have normally already been adjusted in the commissioning menu (see page 20).



Note

If the setting is changed later on, all adjustments for the solar part of the arrangement will be set back to their factory settings.

If the change causes the solar system to require a relay or PWM / 0-10V output that has been allocated to an arrangement or heating function before, the relay / PWM/0-10 V output is removed from the non solar function.

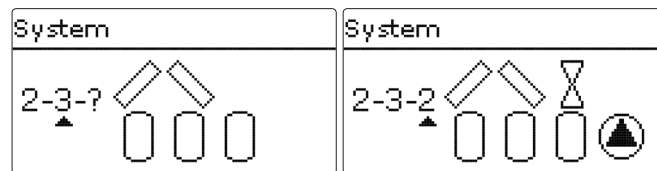

The controller supports up to 3 collector fields and up to 5 solar stores (with 2 or 3 collector fields only up to 4 solar stores).

The following items in the **Solar / Basic setting** menu will adjust to the system selected.

Collector (1/2/3)

| | |
|---|--------|
| Collector | ▼ |
| ▶ <input checked="" type="checkbox"/> Colmin. | |
| Colmin. | 10 °C |
| Colem. | 130 °C |

Solar / Basic setting / Collector (1/2/3)

| Adjustment channel | Description | Adjustment range/selection | Factory setting |
|--------------------|---------------------------------|----------------------------|-----------------|
| Colmin. | Collector minimum limitation | Yes, No | Yes |
| Colmin. | Minimum collector temperature | 10 ... 90 °C | 10 °C |
| Colem. | Collector emergency temperature | 80 ... 200 °C | 130 °C |

In systems with 2 or 3 collector fields, up to 3 separate menu items (Collector 1 to Collector 3) are displayed instead of **Collector**.

For each collector field, a collector minimum limitation and a collector emergency shutdown temperature can be adjusted.

Collector minimum limitation

If the collector minimum limitation option is activated, the corresponding pump is only switched on if the adjustable minimum collector temperature is exceeded. A hysteresis of 2 K is set for this function.



Note

If the store cooling or antifreeze function is active, the collector minimum limitation is overridden. In this case, the collector temperature may fall below the minimum temperature.

Collector emergency shutdown

When the collector temperature exceeds the adjusted collector emergency temperature, the corresponding pump switches off in order to protect the system components against overheating. A hysteresis of 10 K is set for the collector emergency temperature.

Store (1/2/3/4/5)

| | |
|--------|--------|
| Store | ▼ |
| ▶ ΔTOn | 6.0 K |
| ΔTOff | 4.0 K |
| ΔTSet | 10.0 K |

Solar / Basic setting / Store (1/2/3/4/5)

| Adjustment channel | Description | Adjustment range/selection | Factory setting |
|--------------------|--|--------------------------------|------------------|
| ΔTOn | Switch-on temperature difference | 1.0 ... 20.0 K | 6.0 K |
| ΔTOff | Switch-off temperature difference | 0.5 ... 19.5 K | 4.0 K |
| ΔTSet | Set temperature difference | 1.5 ... 30.0 K | 10.0 K |
| Stset | Set store temperature | 4 ... 95 °C | 45 °C |
| Stmax | Maximum store temperature | 4 ... 95 °C | 60 °C |
| Priority | Store priority | 1 ... 5 | system dependent |
| HysSt | Hysteresis set and maximum store temperature | 0.1 ... 10.0 K | 2.0 K |
| Rise | Rise value | 1.0 ... 20.0 K | 2.0 K |
| tMin | Minimum runtime | 0 ... 300 s | 30 s |
| Min. speed | Minimum speed | 20 ... 100% | 30% |
| Store | Blocked for solar loading | Activated, Deactivated, Switch | Activated |
| Sensor | Switch input selection | - | - |

In systems with 2 or more stores, the corresponding number of separate menu items (**Store 1 to Store 5**) is displayed instead of **Store**.

For each store, an individual ΔT control, a set and a maximum temperature, the priority (in multi-store systems), a hysteresis, a rise value, a minimum runtime and a minimum pump speed can be adjusted.

The ΔT control works as a standard differential control. If the temperature difference reaches or exceeds the switch-on temperature difference, the corresponding pump switches on. When the temperature difference reaches or falls below the adjusted switch-off temperature difference, the corresponding output switches off.



Note

The switch-on temperature difference must be at least 0.5 K higher than the switch-off temperature difference.

In multi-store-systems with differing set store / maximum store temperatures, all stores are first loaded up to their set store temperatures, then up to their maximum store temperatures (according to their priority and the store sequence control). If one of the stores does not reach its set temperature, e.g. because the temperature difference is not sufficiently high, the subsequent store will be loaded past its set temperature up to its maximum temperature, if the switch-on condition is fulfilled (does not apply if successive loading has been selected).

The store number refers to the corresponding store sensor, not to the priority of the store. In the **Priority** channel, the corresponding store number is suggested as factory setting, but may be changed at will.

If stores have been adjusted to identical values, they are loaded in parallel.

The store numbers refer to the sensors as follows:

Store 1 = Sensor S2

Store 2 = Sensor S4

Store 3 = Sensor S5

Store 4 = Sensor S6 or S7

Store 5 = Sensor S7

Each loading process will be carried out for the duration of the minimum runtime at least, regardless of the switch-off condition.



Note

In order to prevent system damage, the controller is also equipped with an integrated store emergency shutdown, deactivating the whole solar system as soon as one of the stores reaches 95 °C [200 °F].

Loading logic

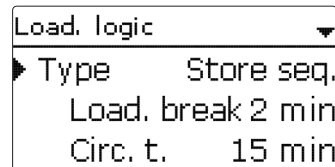

Solar / Basic setting / Load. logic

| Adjustment channel | Description | Adjustment range / selection | Factory setting |
|--------------------|---|------------------------------|-----------------|
| Type | Loading logic type | Store seq./Succ. loading | Store seq. |
| Load. break | Loading break time | 1 ... 5 min | 2 min |
| Circ. t. | Circulation time | 1 ... 60 min | 15 min |
| Break speed | Break speed option | Yes, No | No |
| Speed | Loading break time speed | 20 ... 100% | 30% |
| Spreaded loading | Spreaded loading option | Yes, No | No |
| ΔT | Spreaded loading temperature difference | 20 ... 90 K | 40 K |
| Pump delay | Pump delay | Yes, No | No |
| Delay | Delay time | 5 ... 600 s | 15 s |

In systems with 2 or more stores, loading logic adjustments can be made in this menu.

In systems with 1 store, only the menu item **Pump delay** is available.

Each loading process will be carried out for the minimum runtime (**Solar/Basic setting / Store**) at least, regardless of the switch-off condition.

Store sequence control type

If the priority store cannot be loaded, the subordinate store next in priority will be checked. If useful heat can be added, it will be loaded for the circulation time. After the circulation time has elapsed, the loading process will stop and the controller will monitor the increase in collector temperature during the loading break time. If it increases by 2 K, the break time timer will start again to allow the collector to gain more heat. If the collector temperature does not increase sufficiently, the subordinate store will be loaded again for the circulation time as before.

As soon as the switch-on condition of the priority store is fulfilled, it will be loaded. If the switch-on condition of the priority store is not fulfilled, loading of the subordinate store will be continued. If the priority store reaches its maximum temperature, store sequence control will not be carried out.

Successive loading type

Successive loading means that the priority store will be loaded up to its maximum temperature. If it is reached, the next store available for heating will be loaded. If the temperature of the priority store falls below the set store temperature, the next store will no longer be loaded, regardless of whether the switch-on conditions of the priority store or of the subordinate store are fulfilled or not.

If all stores have been loaded to their set temperatures, the same process will take place until the stores have reached their maximum temperatures.

Spreaded loading option

In multi-store systems without 3-port valves, a spreaded loading function can be activated: As soon as the adjustable temperature difference between the collector and the priority store is exceeded, the next store will be loaded in parallel unless it is blocked. If the temperature difference falls by 2 K below the adjusted value, the pump will be switched off.

Relay

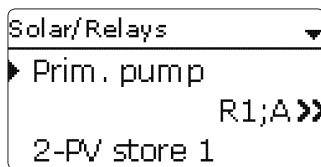

Solar / Basic setting / Relay

| Adjustment channel | Description | Adjustment range / selection | Factory setting |
|--------------------|-------------------------|------------------------------|------------------|
| Relay | Relay display | system dependent | system dependent |
| PWM/0-10V | PWM/0-10V option | Yes, No | No |
| Output | Signal output selection | system dependent | system dependent |
| Signal | Signal type | PWM, 0-10 V | PWM |
| Profile | Curve | Solar, Heating | Solar |
| Speed | Speed control | Yes, No | system dependent |
| Min. | Minimum speed | 20 ... 100% | 20% |
| Max. | Maximum speed | 20 ... 100% | 100% |

| Adjustment channel | Description | Adjustment range / selection | Factory setting |
|--------------------|----------------------------|------------------------------|-----------------|
| Adapter | Adapter option | Yes, No | No |
| Inverted | Inverted switching option | Yes, No | No |
| Blocking protect. | Blocking protection option | Yes, No | No |
| Manual mode | Operating mode | Max., Auto, Min., Off | Auto |

This submenu indicates the components to which the outputs of the system selected have been allocated. All adjustments required for the outputs can be made in this menu.

8.2 Optional functions

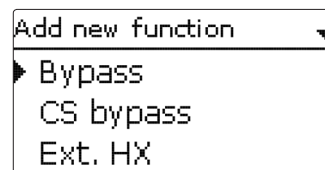

In this menu, additional functions can be selected and adjusted for the solar part of the arrangement.

The kind and number of optional functions offered depends on the previous adjustments.



Note

For further information about adjusting optional functions, see page 14.

Bypass

| | |
|-------------|------|
| Bypass | |
| ▶ Collector | 1 |
| Output | R.3 |
| Type | Pump |

Pump type

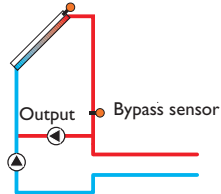

Valve type

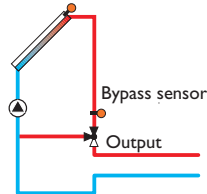

Valve type (inverted)

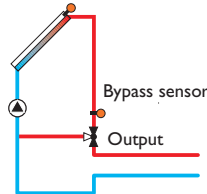

Exemplary schematics for the bypass variants

Solar / Opt. functions / Add new function / Bypass

| Adjustment channel | Description | Adjustment range/selection | Factory setting |
|--------------------|--|--------------------------------|------------------|
| Collector | Collector field | system dependent | system dependent |
| Output | Bypass output | system dependent | system dependent |
| Type | Variant (pump or valve logic) | Pump,Valve | Pump |
| Inverted | Valve logic inversion | Yes, No | No |
| Sensor | Bypass sensor | system dependent | system dependent |
| ΔT_{On} | Bypass switch-on temperature difference | 1.0 ... 20.0K | 6.0K |
| ΔT_{Off} | Bypass switch-off temperature difference | 0.5 ... 19.5K | 4.0K |
| Funct. | Activation / Deactivation | Activated, Deactivated, Switch | Activated |
| Sensor | Switch input selection | - | - |

| Adjustment channel | Description | Adjustment range/selection | Factory setting |
|-------------------------------|-------------------------|----------------------------|-----------------|
| Save function/Delete function | Save or delete function | - | - |

This function can be used for avoiding an energy loss directly after the solar circuit has been switched on. The still cold heat transfer medium in the pipework is diverted through a bypass past the store. Once the fluid is warm enough, the store can be loaded.

| |
|--|
| Type |
| ▶ <input checked="" type="radio"/> Valve |
| <input type="radio"/> Pump |

Depending on whether the bypass is energised by a valve or by a second pump, a corresponding adjustment can be made in the menu item **Type**. Depending on the variant, different control logics are applied:

Pump type

In this version, a bypass pump is placed in front of the solar pump.

The bypass pump is first activated when store loading is possible. If the temperature difference between the bypass sensor and the store sensor reaches the switch-on temperature difference, the bypass pump is switched off and the solar pump is switched on instead.

Valve type

In this version, a bypass valve is placed into the solar circuit.

The valve initially remains switched so that the bypass is active when store loading is possible. If the temperature difference between the bypass sensor and the store sensor reaches the switch-on temperature difference, the bypass relay operates the valve and solar loading starts.

When the valve type is selected, the **Inverted** option is additionally available. When the Inverted option and the bypass circuit are activated, the relay switches on. If the temperature difference between the bypass sensor and the store sensor reaches the switch-on temperature difference, the relay switches off.

| | |
|-------------|----------------------|
| CS bypass | |
| ▶ Collector | 1,2 |
| Irrad. | 200 W/m ² |
| Delay | 120 s |

Solar / Opt. functions / Add new function / CS bypass

| Adjustment channel | Description | Adjustment range/selection | Factory setting |
|-------------------------------|---------------------------|--------------------------------|----------------------|
| Collector | Collector field | system dependent | system dependent |
| Irrad. | Switch-on irradiation | 100 ... 500 W/m ² | 200 W/m ² |
| Delay | Delay time | 10 ... 300 s | 120 s |
| Stmax off | Switch-on suppression | Yes, No | Yes |
| Funct. | Activation / Deactivation | Activated, Deactivated, Switch | Activated |
| Sensor | Switch input selection | - | - |
| Save function/Delete function | Save or delete function | - | - |

This function is a further possibility to activate the solar circuit.

**Note**

To enable the use of the CS bypass function, a CS10 irradiation sensor has to be connected.

When the CS bypass function is activated, the irradiation value is the switch-on condition for the collector circuit.

The output switches on if the irradiation value is exceeded for the delay time. If the irradiation falls below the adjusted irradiation value for the adjusted delay, the output switches off.

If the switch-on suppression option off is activated, collector circuit activation will be suppressed as long as all store temperatures are above their respective maximum temperatures.

**Note**

If both the CS bypass and the bypass function are activated, the CS bypass will only affect the bypass. For this purpose, use S1 as the bypass sensor.

External heat exchanger

| | |
|-----------|-----|
| Ext. HX | |
| ▶ Output | R4 |
| Store | 1,2 |
| Sensor HX | S4 |

Solar / Opt. functions / Add new function / Ext. HX

| Adjustment channel | Description | Adjustment range/selection | Factory setting |
|-------------------------------|--|----------------------------|------------------|
| Output | Output selection | system dependent | system dependent |
| Store | Store selection | system dependent | all stores |
| Sensor HX | Reference sensor external heat exchanger | system dependent | system dependent |
| Target temp. | Target temperature option | Yes, No | No |
| Sensor | Target temperature reference sensor | system dependent | system dependent |
| Targ. temp. | Target temperature | 15 ... 95 °C | 60 °C |
| ΔTON | Switch-on temperature difference | 1.0 ... 20.0 K | 10.0 K |
| ΔTOFF | Switch-off temperature difference | 0.5 ... 19.5 K | 5.0 K |
| Overrun | Overrun time | 0 ... 15 min | 2 min |
| Save function/Delete function | Save or delete function | - | - |

This function is used to link loading circuits that are separated by an external heat exchanger.

The allocated output is energised if one of the selected stores is being loaded and there is a temperature difference between the sensor of the corresponding store and the reference sensor external heat exchanger.

Any number of the solar stores can be selected.

The output is switched off if this temperature difference falls below the adjusted switch-off difference.

**Note**

In systems in which stores are equipped with their own loading pumps, the heat exchanger relay controls the primary circuit pump.

If the **Target temp.** option is activated, the pump speed control logic will change. The controller will remain at the minimum pump speed until the temperature at the allocated sensor exceeds the adjusted target temperature.

If the temperature at the reference sensor target temperature exceeds the target temperature by 5K, the speed of the primary pump will be increased by 10%. If the temperature again increases by 5K, the speed of the secondary pump will be adapted, too. Each temperature increase by 5K will lead to an alternating adaptation of the primary and secondary pump speeds. If the temperature falls, the speed will be reduced correspondingly.



Note

The heat exchanger is protected by a non-adjustable antifreeze function. Still, using a bypass is recommended.

The heat exchanger is protected by a non-adjustable antifreeze function. If the temperature at the heat exchanger sensor falls below the antifreeze temperature (10 °C), the controller will activate the secondary pump at 100 % speed. The antifreeze function will use heat from the store with the highest temperature. When all stores have reached 10 °C, the secondary pump will be switched off. If the temperature at the reference sensor exceeds the antifreeze temperature by 2K, the secondary pump will be switched off.

The heat exchanger antifreeze function works independently from solar loading.



Note

Because of the special hydraulics in systems with 2 or 3 collector fields, the target temperature option will not work properly there.

Tube collector function

| Tube collector | |
|----------------|-------|
| Start | 08:00 |
| Stop | 19:00 |
| Run | 30 s |

Solar / Opt. functions / Add new function / Tube collector

| Adjustment channel | Description | Adjustment range/se-lection | Factory setting |
|--------------------|------------------|-----------------------------|-----------------|
| Start | Start time frame | 00:00 ... 23:00 | 08:00 |
| Stop | Stop time frame | 00:30 ... 23:30 | 19:00 |
| Run | Pump runtime | 5 ... 600 s | 30 s |

| Adjustment channel | Description | Adjustment range/se-lection | Factory setting |
|----------------------------------|---------------------------|--------------------------------|-------------------|
| Break | Standstill interval | 1 ... 60 min | 30 min |
| Collector | Collector field | system dependent | system depend-ent |
| Stmax off | Switch-on suppression | Yes, No | Yes |
| Funct. | Activation / Deactivation | Activated, Deactivated, Switch | Activated |
| Sensor | Switch input selection | - | - |
| Save func-tion / Delete function | Save or delete function | - | - |

This function is used for improving the switch-on behaviour in systems with non-ideal sensor positions (e.g. with some tube collectors).

This function operates within an adjusted time frame. It activates the collector circuit pump for an adjustable runtime between adjustable standstill intervals in order to compensate for the delayed temperature measurement.

If the runtime is set to more than 10 s, the pump will run at 100% for the first 10 s of the runtime. For the remaining runtime, the pump will run at the adjusted minimum speed.

If the collector sensor is defective or the collector is blocked, this function is suppressed or switched off.

If the switch-on suppression is activated and all stores have exceeded their respective maximum temperature, the tube collector function will be suppressed.

2- and 3-collector systems

In systems with 2 or 3 collector fields, the tube collector function will be available for each individual collector field.

The tube collector function will remain inactive for a collector field which is used for solar loading.

Target temperature

| | |
|---------------|-------|
| Target temp. | ▼ |
| ▶ Targ. temp. | 65 °C |
| Sensor | S4 |
| Rise | 2.0 K |

Solar / Opt. functions / Add new function / Target temp.

| Adjustment channel | Description | Adjustment range/selection | Factory setting |
|-------------------------------|---------------------------|--------------------------------|------------------|
| Targ. temp. | Target temperature | 20 ... 110 °C | 65 °C |
| Sensor | Reference sensor | system dependent | system dependent |
| Rise | Rise value | 1.0 ... 20.0K | 2.0K |
| Funct. | Activation / Deactivation | Activated, Deactivated, Switch | Activated |
| Sensor | Switch input selection | - | - |
| Save function/Delete function | Save or delete function | - | - |

If this function is activated, the pump speed control logic will change. The controller will remain at the minimum pump speed until the temperature at the allocated sensor exceeds the adjusted target temperature. Only then will the standard pump speed control start to operate. If the temperature at the allocated sensor changes by 1/10 of the adjusted rise value, the pump speed will be adjusted correspondingly. If the **Ext. HX** function with the **Targ. temp.** option (see page 52) is additionally activated, the target temperature control will pause while the external heat exchanger is being loaded. While the external heat exchanger is loaded, its own pump speed control will come into effect.

Antifreeze

| | |
|--------------|------|
| Antifreeze | ▼ |
| ▶ Antifr. on | 4 °C |
| Antifr. off | 6 °C |
| Collector | 1,2 |

Solar / Opt. functions / Add new function / Antifreeze

| Adjustment channel | Description | Adjustment range/selection | Factory setting |
|-------------------------------|---------------------------|--------------------------------|------------------|
| Antifr. on | Switch-on temperature | -40 ... +15 °C | +4 °C |
| Antifr. off | Switch-off temperature | -39 ... +16 °C | +6 °C |
| Collector | Collector field | system dependent | system dependent |
| Store (1 ... 5) | Store succession order | system dependent | system dependent |
| Funct. | Activation / Deactivation | Activated, Deactivated, Switch | Activated |
| Sensor | Switch input selection | - | - |
| Save function/Delete function | Save or delete function | - | - |

This function activates the loading circuit between the collector and the store when the collector temperature falls below the adjusted switch-on temperature. This will protect the fluid against freezing or coagulating. If the switch-off temperature is exceeded, the solar pump will be switched off again.

Heat will be extracted from the stores according to the adjusted order. When all stores have reached their minimum temperature of 5 °C, the function becomes inactive.

If the function is activated, the pump will run at its maximum relative speed.

**Note**

Since this function uses the limited heat quantity of the store, the antifreeze function should be used in regions with few days of temperatures around the freezing point.

This function should only be used in systems which do not use any antifreeze.

**Note**

In systems with 2 or 3 collector fields, 2 or 3 separate menus will be displayed.

Backup heating suppression

```

BH suppress.
▶ Output      R4
  Store      1,2
   Stset
    
```

Solar / Opt. functions / Add new function / BH suppress.

| Adjustment channel | Description | Adjustment range/selection | Factory setting |
|-------------------------------|---------------------------|--------------------------------|------------------|
| Output | Reference output | system dependent | system dependent |
| Store | Store selection | system dependent | system dependent |
| Stset | Set store temperature | Yes, No | No |
| Funct. | Activation / Deactivation | Activated, Deactivated, Switch | Activated |
| Sensor | Switch input selection | - | - |
| Save function/Delete function | Save or delete function | - | - |

This function blocks the conventional backup heating of a store that is currently in solar loading.

This function is activated if a previously selected store is being loaded by solar heat. Solar loading means that store loading is only carried out for energy supply and not for cooling purposes etc.

If the **Stset** option is activated, the backup heating will only be suppressed when the store temperature exceeds the set store temperature.

Parallel relay

```

Parallel relay
▶ Output      R4
  Store      1
  Funct.     Activated
    
```

Solar / Opt. functions / Add new function / Parallel relay

| Adjustment channel | Description | Adjustment range/selection | Factory setting |
|-------------------------------|---------------------------|--------------------------------|------------------|
| Output | Parallel output | system dependent | system dependent |
| Store | Store selection | system dependent | system dependent |
| Funct. | Activation / Deactivation | Activated, Deactivated, Switch | Activated |
| Sensor | Switch input selection | - | - |
| Save function/Delete function | Save or delete function | - | - |

With this function, e.g. a valve can be controlled in parallel to a solar pump via a separate output.

Switch-on condition for the solar parallel relay function is that one or more of the selected stores is being loaded. If one of the selected stores is being loaded, the parallel output will be energised.

The parallel relay function operates regardless whether the store is subjected to regular solar loading or to a loading caused by a solar optional function (such as the collector cooling).



Note

If a relay is in the manual mode, the selected parallel output will not be energised.

Cooling mode

| Cooling mode | |
|--------------|-------------|
| Type | Syst. cool. |
| Store 1 | 1 |
| Store 2 | 2 |

Solar / Opt. functions / Add new function / Cooling mode

| Adjustment channel | Description | Adjustment range/selection | Factory setting |
|--------------------------------|-----------------------------------|--------------------------------|------------------|
| Type | Cooling logic variant | Col. cool., Syst. cool., Off | Off |
| TColmax. | Collector maximum temperature | 70 ... 190 °C | 100 °C |
| Store (1 ... 5) | Store succession order | system dependent | system dependent |
| St. cooling | Store cooling option | Yes, No | No |
| ΔT_{On} | Switch-on temperature difference | 1.0 ... 30.0 K | 20.0 K |
| ΔT_{Off} | Switch-off temperature difference | 0.5 ... 29.5 K | 15.0 K |
| Funct. | Activation / Deactivation | Activated, Deactivated, Switch | Activated |
| Sensor | Switch input selection | - | - |
| Save function/ Delete function | Save or delete function | - | - |

In the **Cooling mode** menu, different cooling functions are available. They can be used for keeping the solar system operational for a longer time during strong solar irradiation.

For this purpose, the adjusted maximum store temperatures can be exceeded. The store order for this overloading can be adjusted. Additionally, each individual store can be excluded from this function.

2 Variants are available for the cooling mode: System cooling and Collector cooling.

System cooling type

If the switch-on temperature difference is exceeded, store loading will be continued

even if the corresponding maximum temperature is exceeded, but only up to the emergency shutdown temperature. Store loading will continue until all stores have reached the emergency shutdown temperature or until the switch-off temperature difference is reached.

Collector cooling type

If the collector maximum temperature is exceeded, the stores will be loaded above their respective maximum temperature.

Store loading will continue until all stores have reached the emergency shutdown temperature or until the collector temperature falls below the collector maximum temperature by at least 5 K.

In systems with 2 or 3 collector fields, separate adjustments can be made for each collector field.

The control logic considers collector cooling operation to be solar loading. The adjusted values for delay, minimum runtime etc. remain valid.

Additionally to each of the two variants, the store cooling option can be activated.

Store cooling option

When the store cooling option is activated, the controller aims to cool down the store during the night in order to prepare it for solar loading on the following day.

The store cooling option is active, if the maximum store temperature is exceeded. If, in addition to that, the collector temperature falls below the store temperature, the solar pump switches on. The solar pump remains active until the store temperature falls below the adjusted maximum store temperature.

The store order for the cooling is the same as in the overheating through system- or collector cooling.

Drainback option

| Drainback | |
|--------------|---------|
| Filling time | 5 min |
| Stab. time | 2.0 min |
| Initialis. | 60 s |

Solar / Opt. functions / Add new function / Drainback

| Adjustment channel | Description | Adjustment range/selection | Factory setting |
|--------------------|------------------------|----------------------------|-----------------|
| Filling time | Drainback filling time | 1 ... 30 min | 5 min |
| Stab. time | Stabilisation time | 1.0 ... 15.0 min | 2.0 min |

| Adjustment channel | Description | Adjustment range/selection | Factory setting |
|-------------------------------|--------------------------------|--------------------------------|------------------|
| Initialis. | Initialisation time | 1 ... 100 s | 60 s |
| Booster | Booster option | Yes, No | No |
| Output | Output selection booster pump | system dependent | system dependent |
| Drain impulse | Drain impulse option | Yes, No | No |
| Delay | Delay time | 1 ... 30 min | 3 min |
| Duration | Drain impulse loading duration | 1 ... 60 s | 10 s |
| Funct. | Activation / Deactivation | Activated, Deactivated, Switch | Deactivated |
| Sensor | Switch input selection | - | - |
| Save function/Delete function | Save or delete function | - | - |

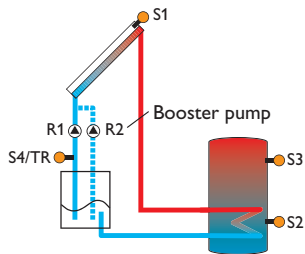

Exemplary drainback system layout (R2 = booster pump)

In a drainback system the heat transfer fluid will flow into a holding tank if solar loading does not take place. The drainback option initiates the filling process if solar loading is about to start.

Note A drainback system requires additional components such as a holding tank. The drainback option should only be activated if all components required are properly installed.

The filling time can be adjusted using the parameter **Filling time**. During this period, the pump runs at 100 % speed.

The parameter **Stab. time** is used for adjusting the time period during which the switch-off condition will be ignored after the filling time has ended.

The parameter **Initialis.** is used for adjusting the period during which the switch-on condition must be permanently fulfilled, before the filling process starts.

The **Booster** option is used for switching on a second pump when filling the solar system. The corresponding output is switched on at 100 % speed for the duration of the filling time.

After the system has been emptied and the delay time elapsed, the **Drain impulse** option will switch on the solar pump for an adjustable duration. Thus, a hydrostatic head will form in the flow pipe. When it falls back into the holding tank, water pockets remaining in the collector will be sucked down into the holding tank.

Note If the drainback option is used in multi store systems, the **Break speed** option has to be activated in the **Solar/Basic setting/Load. logic** menu!

Twin pump

| Twin pump | |
|------------|-----|
| Output | R4 |
| Ref. relay | R3 |
| Runtime | 6 h |

Solar / Opt. functions / Add new function / Twin pump

| Adjustment channel | Description | Adjustment range/selection | Factory setting |
|-------------------------------|-----------------------------|--|------------------|
| Output | Twin pump output selection | system dependent | system dependent |
| Ref. relay | Reference relay selection | system dependent | - |
| Runtime | Pump runtime | 1 ... 48 h | 6 h |
| Flow rate mon. | Flow rate monitoring option | Yes, No | No |
| Sen. flow rate | Flow rate sensor selection | IMP1 ... IMP3, Ga1, Ga2, Gd1, Gd2, FR1 | - |
| Delay | Delay time | 1 ... 10 min | 5 min |
| Funct. | Activation / Deactivation | Activated, Deactivated, Switch | Activated |
| Sensor | Switch input selection | - | - |
| Save function/Delete function | Save or delete function | - | - |

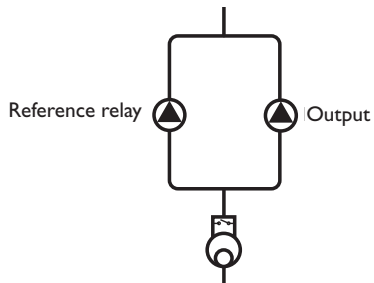

Exemplary figure of twin pumps in the solar flow with upstream flowmeter

This function controls the equal distribution of pump runtime in systems with 2 equally usable pumps.

If the selected reference relay has exceeded the adjusted runtime, the allocated output (twin pump) is switched on in the next switch-on process. All characteristics are adopted.

If the allocated output has in turn exceeded its runtime as well, the selected reference relay is switched on again in the next switch-on process.

Additionally, flow rate monitoring can be activated in order to activate the twin pump in case of a flow rate error. If flow rate monitoring is activated, an error message appears when no flow rate is detected at the allocated sensor after the delay time has elapsed. The active output is considered defective and is blocked until the error message has been acknowledged. The second output is activated instead. The twin pump function no longer takes place until the error message has been acknowledged.

When the error message is acknowledged, the controller runs a test during which it energises the corresponding output and again monitors the flow rate.

Heat dump

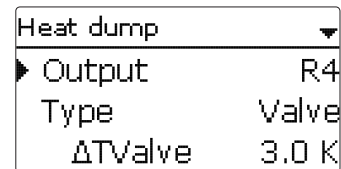

Solar / Opt. functions / Add new function / Heat dump

| Adjustment channel | Description | Adjustment range/selection | Factory setting |
|--------------------------------|-----------------------------------|--------------------------------|------------------|
| Output | Output selection | system dependent | system dependent |
| Type | Variant (pump or valve logic) | Valve, Pump | Valve |
| ΔTValve | Temperature difference valve open | 0.0 ... 10.0K | 3.0K |
| Collector | Collector selection | system dependent | 1 |
| TCol. | Collector overtemperature | 40 ... 190 °C | 110 °C |
| Funct. | Activation / Deactivation | Activated, Deactivated, Switch | Activated |
| Sensor | Switch input selection | - | - |
| Save function/ Delete function | Save or delete function | - | - |

Pump type

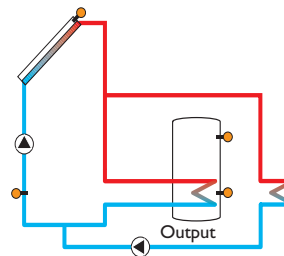

Valve type

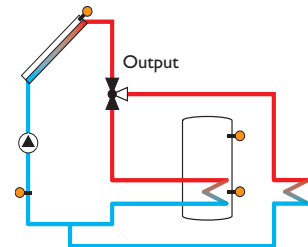

This function can be used to direct excess heat generated by strong solar irradiation to an external heat exchanger (e.g. fan coil) in order to keep the collector temperature within the operating range.

Whether the heat dump is activated via an additional pump or a valve can be adjusted in the **Type** menu.

Pump type

The allocated output will be energised with 100%, if the collector temperature reaches the adjusted switch-on temperature.

If the collector temperature falls by 5 K below the adjusted collector overtemperature, the output will be switched off. In the pump variant, the heat dump function works independently from solar loading.

Valve type

If the collector temperature reaches the value [TCol. - ΔTValve], the allocated output will be switched on in order to open the valve. If the collector temperature reaches the collector overtemperature, the solar pump will be activated. If the collector temperature falls by 5 K below the adjusted collector overtemperature, the solar pump will be switched off again. If the collector temperature falls by 10 K below the switch-on temperature, the valve will be put into its initial position.

If one of the store temperatures exceeds its store maximum temperature by more than 10 K while the heat dump function is active, the function will be deactivated and an error message will appear. If the temperature falls below this value by the hysteresis (**Solar / Basic setting / Store**), the heat dump function will be released again.



Note

The switch-on collector temperature must be adjusted at least by 10 K lower than the emergency switch-off temperature.

Flow rate monitoring

```

Flow rate mon.
└─▶ Sensor      IMP1
    Ref. relay   R4
    Store       1
  
```

Solar / Opt. functions / Add new function / Flow rate mon.

| Adjustment channel | Description | Adjustment range/selection | Factory setting |
|-------------------------------|----------------------------|--------------------------------|-----------------|
| Sensor | Flow rate sensor selection | system dependent | - |
| Ref. relay | Reference relay selection | system dependent | - |
| Store | Store selection | system dependent | 1 |
| Time | Delay time | 1 ... 300 s | 30 s |
| Funct. | Activation / Deactivation | Activated, Deactivated, Switch | Activated |
| Sensor | Switch input selection | - | - |
| Save function/Delete function | Save or delete function | - | - |

This function can be used to detect malfunctions that impede the flow rate and to switch off the corresponding output. This will prevent system damage, e.g. through a dry run of the pump.

If the flow rate monitoring function is activated, an error message will appear when no flow rate is detected at the allocated flow rate sensor after the delay time has elapsed.

- If a reference relay has been selected, the flow rate monitoring function will become active when the allocated relay switches on. In case of an error, the complete solar system will be shut down.
- If both a store and a reference relay have been selected, the flow rate monitoring function will become active when the allocated relay switches on. In case of an error, the allocated store will be blocked until the error message has been acknowledged. The next store free for loading will be loaded instead.

The error message will appear both in the **Status / Messages** menu and in the **Status / Solar / Flow rate mon.** menu.

Pressure monitoring

```

Pressure monit.
└─▶ Sensor      Gd1
     Low pressure
     Overpressure
  
```



Note

The pressure monitoring function will only work when an RPD / RPS type Grundfos Direct Sensor™ is connected.

Solar / Opt. functions / Add new function / Pressure monit.

| Adjustment channel | Description | Adjustment range/selection | Factory setting |
|--------------------|--------------------------------|----------------------------|-----------------|
| Sensor | Pressure sensor selection | Ga1, Ga2, Gd1, Gd2 | - |
| Low pressure | Low pressure monitoring option | Yes, No | No |
| On | Switch-on threshold | 0.0 ... 9.7 bar | 0.7 bar |
| Off | Switch-off threshold | 0.1 ... 9.8 bar | 1.0 bar |
| Shutdown | Shutdown option | Yes, No | No |
| Overpressure | Overpressure monitoring option | Yes, No | No |
| On | Switch-on threshold | 0.3 ... 10.0 bar | 5.5 bar |

| Adjustment channel | Description | Adjustment range/selection | Factory setting |
|-------------------------------|---------------------------|--------------------------------|-----------------|
| Off | Switch-off threshold | 0.2 ... 9.9 bar | 5.0 bar |
| Shutdown | Shutdown option | Yes, No | No |
| Funct. | Activation / Deactivation | Activated, Deactivated, Switch | Activated |
| Sensor | Switch input selection | - | - |
| Save function/Delete function | Save or delete function | - | - |

This function can be used for detecting overpressure or low pressure conditions inside the system, and if necessary to shut down the affected system components in order to avoid system damage.

Low pressure monitoring

If the system pressure falls below the adjustable switch-on value **On**, an error message will appear.

If the **Shutdown** option has been activated for the low pressure monitoring function, the solar system will be shut down as well in case of a fault condition.

When the pressure reaches or exceeds the adjustable switch-off value **Off**, the system is switched on again.



Note

For the **Low pressure** monitoring function, **Off** always is at least 0.1 bar higher than **On**. The corresponding adjustment ranges will automatically adapt to that.

Overpressure monitoring

If the system pressure exceeds the adjustable switch-on value **On**, an error message will appear.

If the **Shutdown** option has been activated for the overpressure monitoring function, the solar system will be shut down as well in case of a fault condition.

When the pressure reaches or falls below the adjustable switch-off value **Off**, the system is switched on again.



Note

For the **Overpressure** monitoring function, **On** always is at least 0.1 bar higher than **Off**. The corresponding adjustment ranges will automatically adapt to that.

8.3 Function control

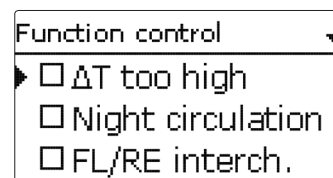

Note

Only if the installer code is entered (see page 91), will the function control menu be available.

Solar / Function control

| Adjustment channel | Description | Adjustment range/selection | Factory setting |
|--------------------|---|----------------------------|------------------|
| ΔT too high | ΔT monitoring option | Yes, No | No |
| Night circulation | Night circulation monitoring option | Yes, No | No |
| FL/RL interch. | FL/RE interchange monitoring option | Yes, No | No |
| Stmax | Maximum store temperature monitoring option | Yes, No | Yes |
| Store | Store selection | system dependent | system dependent |

ΔT monitoring option

This function is used for monitoring the temperature difference. The message **ΔT too high** will be shown if solar loading has been carried out for a period of 20 min with a differential higher than 50 K. Normal operation is not cancelled or inhibited, but the system should be checked for the cause of the warning.

Possible causes are:

- pump power too weak
- hydraulic blockage of a system component
- circulation problems in the collector
- air inside the system
- defective valve / defective pump

Night circulation

This function can be used for detecting thermal circulation inside the solar circuit that leads to an unwanted cooling of the store. A warning message appears when one of the following conditions has been detected for at least 1 min during the

period between 11 p.m. and 5 a.m.:

- collector temperature exceeds 40 °C
- the temperature difference exceeds ΔT_{On}

The delay time of 1 min ensures that the message is not triggered by short-term fault conditions.

Possible causes are:

- defective non-return valves
- defective valve
- wrongly adjusted time

Flow and return interchanged

This function is used for detecting an interchange of the flow and return pipe or a badly placed collector sensor. For this purpose, the collector temperature is monitored for plausibility during the switch-on phases of the solar pump. The message **FL / RE interch.** appears, when the plausibility criteria have not been met 5 times in a row.



Note

The **!FL/RE interch.** error can only be correctly detected and indicated, if the collector sensor measures the temperature directly in the fluid at the collector outlet. If the collector sensor is not correctly placed, a false message may occur.

- ➔ Place the collector sensor directly in the fluid at the collector outlet or deactivate the **FL/RE interch.** function control.

Maximum store temperature

This function is used for detecting and indicating if the adjusted maximum store temperature has been exceeded. The controller compares the current store temperature to the adjusted maximum store temperature, thus monitoring the store loading circuits.

The maximum store temperature is considered exceeded when the temperature measured at the store sensor exceeds the adjusted maximum store temperature by at least 5 K. The monitoring becomes active again as soon as the store temperature falls below the adjusted maximum store temperature.

In the **Store** channel, the store or stores to be monitored can be selected.

A possible cause for an unwanted exceedance of the maximum store temperature is a defective valve.

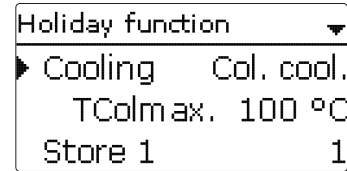

Solar/Holiday function

| Adjustment channel | Description | Adjustment range/selection | Factory setting |
|--------------------|-----------------------------------|------------------------------|------------------|
| Cooling | Cooling logic variant | Col. cool., Syst. cool., Off | Off |
| TColmax. | Collector maximum temperature | 70 ... 190 °C | 100 °C |
| Store (1...5) | Store succession order | system dependent | system dependent |
| St. cooling | Store cooling option | Yes, No | Yes |
| ΔT_{On} | Switch-on temperature difference | 1.0 ... 30.0 K | 20.0 K |
| ΔT_{Off} | Switch-off temperature difference | 0.5 ... 29.5 K | 15.0 K |
| Stmax (1...5) | Store cooling temperature | 4 ... 95 °C | 40 °C |
| Heat dump | Store heat dump | Yes, No | No |
| Output | Output selection | system dependent | - |
| Sensor | Sensor selection | system dependent | - |
| TStoreOn | Switch-on temperature | 5 ... 95 °C | 65 °C |
| TStoreOff | Switch-off temperature | 4 ... 94 °C | 45 °C |

The holiday function is used for operating the system when no water consumption is expected, e.g. during a holiday absence. This function cools down the system in order to reduce the thermal load.

Only if the holiday function has been activated with the parameter **Days of absence** will the adjustments described in the following become active.

The parameter **Days of absence** can be used for entering the number of days for an absence.

- ➔ In order to adjust the days of absence, press and hold down button for 5 s. If the parameter is set to a value higher than 0, the function becomes active using the adjustments that have previously been made in the Holiday menu. The days will be counted backwards at 00:00. If the value is set to 0, the function is deactivated. The remaining days of absence are displayed in the status menu and can be changed there later on.

2 cooling functions are available: System cooling, collector cooling

System cooling type

If the switch-on temperature difference is exceeded, the stores continue to be loaded even if their corresponding maximum temperature is reached, but only up to the emergency shutdown temperature. Store loading continues until all stores have reached the emergency shutdown temperature or until the switch-off temperature difference is reached.

Collector cooling type

If the collector maximum temperature is exceeded, the stores will be loaded above their respective maximum temperature.

Store loading continues until all stores have reached the emergency shutdown temperature or until the collector temperature falls below the collector maximum temperature by at least 5 K.

The control logic regards collector cooling operation as solar loading. The adjusted values for delay, minimum runtime, etc. remain valid.

Additionally to each of the two variants, the store cooling can be activated.

Store cooling option

When the store cooling option is activated, the controller aims to cool down the store during the night in order to prepare it for solar loading on the following day.

The store cooling option is active, if the maximum store temperature is exceeded. If, in addition to that, the collector temperature falls below the store temperature, the solar pump switches on. The solar pump remains active until the store temperature falls below the adjusted maximum store temperature.

The store order for the cooling is the same as in the overheating through system- or collector cooling.

Store heat dump option

This option can be used to direct excess heat generated by strong solar irradiation from the store to an external heat exchanger (e.g. fan coil) or radiator in order to prevent the collectors from overheating. The store heat dump function is independent of the solar system and can be activated with the parameter **Heat dump**. The function uses the adjustable switch-on and switch-off temperature differences **TStoreOn** and **TStoreOff**.

If the temperature measured at the sensor selected reaches the switch-on temperature, the output selected will be energised until the temperature difference falls below the switch-off value.

8.5 Solar expert menu

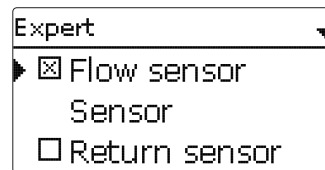

The expert menu is only available when the installer user code has been entered.

Solar / Expert

| Adjustment channel | Description | Adjustment range/selection | Factory setting |
|--------------------|-------------------------|----------------------------|-----------------|
| Flow sensor | Flow sensor option | Yes, No | No |
| Sensor | Flow sensor selection | system dependent | - |
| Return sensor | Return sensor option | Yes, No | No |
| Sensor | Return sensor selection | system dependent | - |

In the expert menu, a flow and a return sensor can be selected and allocated. The activated sensors are then used to detect the switch-off condition.

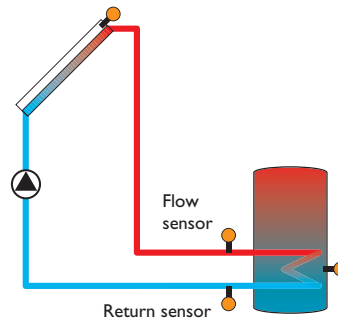

Example of flow and return sensor positions



Note:

Because of the special hydraulics in systems with 2 or 3 collectors, this function will not work properly there.

9 Arrangement

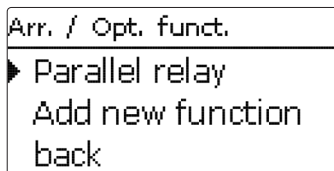

In this menu, all adjustments for the non-solar part of the arrangement can be made. Up to 16 optional functions can be selected and adjusted.

9.1 Optional functions

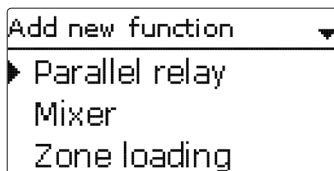

In this menu, optional functions can be selected and adjusted for the arrangement. The kind and number of optional functions offered depends on the previous adjustments.



Note

For further information about adjusting optional functions, see page 14.

Parallel relay

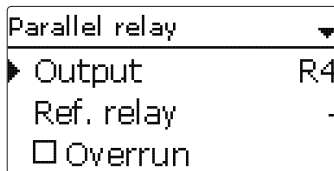

Arrangement / Opt. functions / Add new function / Parallel relay

| Adjustment channel | Description | Adjustment range/selection | Factory setting |
|--------------------|---------------------------|----------------------------|------------------|
| Output | Output selection | system dependent | system dependent |
| Ref. relay | Reference relay selection | system dependent | - |
| Overrun | Overrun option | Yes, No | No |
| Duration | Overrun time | 1 ... 30 min | 1 min |
| Delay | Delay option | Yes, No | No |

| Adjustment channel | Description | Adjustment range/selection | Factory setting |
|---------------------------------|---------------------------|--------------------------------|-----------------|
| Duration | Delay time | 1 ... 30 min | 1 min |
| Funct. | Activation / Deactivation | Activated, Deactivated, Switch | Activated |
| Sensor | Switch input selection | - | - |
| Save function / Delete function | Save or delete function | - | - |

This function can be used for operating an allocated output alongside a selected reference relay. With this function, e.g. a valve can be controlled in parallel to the pump via a separate output.

If the **Overrun** option is activated, the output remains switched on for the adjusted overrun time after the reference relay has been switched off.

If the **Delay** option is activated, the output is energised after the adjusted duration has elapsed. If the reference relay is switched off again during the delay time, the parallel output is not be switched on at all.



Note

If a relay is in the manual mode, the selected output will not be energised.

Mixer

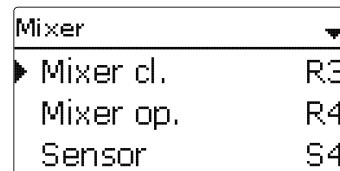

Arrangement / Opt. functions / Add new function / Mixer

| Adjustment channel | Description | Adjustment range/selection | Factory setting |
|---------------------------------|-------------------------------|--------------------------------|------------------|
| Mixer cl. | Output selection mixer closed | system dependent | system dependent |
| Mixer op. | Output selection mixer open | system dependent | system dependent |
| Sensor | Sensor selection | system dependent | system dependent |
| TMixer | Mixer target temperature | 0 ... 130 °C | 60 °C |
| Interval | Mixer interval | 1 ... 20 s | 4 s |
| Funct. | Activation / Deactivation | Activated, Deactivated, Switch | Activated |
| Sensor | Switch input selection | - | - |
| Save function / Delete function | Save or delete function | - | - |

This function can be used to adjust the actual flow temperature to the desired mixer target temperature. The mixer will be opened or closed in pulses depending on this deviation. The mixer will be controlled with the adjustable Interval. The pause is determined by the difference between the actual value and the set value.

Zone loading

| Zone loading | |
|--------------|----|
| ▶ Output | R3 |
| Sensor top | S3 |
| Sensor base | S4 |

Arrangement / Opt. functions / Add new function / Zone loading

| Adjustment channel | Description | Adjustment range/selection | Factory setting |
|---------------------------------|---------------------------|--------------------------------|------------------|
| Output | Output selection | system dependent | system dependent |
| Sensor top | Top sensor selection | system dependent | system dependent |
| Sensor base | Base sensor selection | system dependent | system dependent |
| TOn | Switch-on temperature | 0 ... 94 °C | 45 °C |
| TOff | Switch-off temperature | 1 ... 95 °C | 60 °C |
| Timer | Timer function | Yes, No | No |
| Funct. | Activation / Deactivation | Activated, Deactivated, Switch | Activated |
| Sensor | Switch input selection | - | - |
| Save function / Delete function | Save or delete function | - | - |

This function can be used for loading a store zone between 2 sensors. For monitoring the switch-on and switch-off conditions, 2 sensors are used. The switch-on and switch-off temperatures are used as reference parameters.

If the measured temperatures at both allocated sensors fall below the adjusted switch-on temperature, the output will be energised. The output will be switched off again if the temperature at both sensors has exceeded the switch-off temperature. If one of the two sensors is defective, zone loading is suppressed or switched off.



Note

For information on timer adjustment see page 12.

Error relay

| Error relay | |
|---------------|-----------|
| ▶ Output | R3 |
| Funct. | Activated |
| Save function | |

Arrangement / Opt. functions / Add new function / Error relay

| Adjustment channel | Description | Adjustment range/selection | Factory setting |
|---------------------------------|---------------------------|--------------------------------|------------------|
| Output | Output selection | system dependent | system dependent |
| Funct. | Activation / Deactivation | Activated, Deactivated, Switch | Activated |
| Sensor | Switch input selection | - | - |
| Save function / Delete function | Save or delete function | - | - |

This function can be used for operating an output in case of an error. Thus, e.g. a signalling device can be connected in order to signal errors.

If the error relay function is activated, the allocated output will operate when a fault occurs. If the flow rate monitoring and/or pressure monitoring function is additionally activated, the allocated output will also operate in case of a flow rate or pressure error.

Heat exchange

| | |
|---------------|----|
| Heat exchange | |
| ► Output | R3 |
| Sen. source | S3 |
| Sen. sink | S4 |

Arrangement / Opt. functions / Add new function / Heat exchange

| Adjustment channel | Description | Adjustment range / selection | Factory setting |
|---------------------------------|---|--------------------------------|------------------|
| Output | Output selection | system dependent | system dependent |
| Sen. source | Heat source sensor selection | system dependent | system dependent |
| Sen. sink | Heat sink sensor selection | system dependent | system dependent |
| ΔT_{On} | Switch-on temperature difference | 1.0 ... 30.0 K | 6.0 K |
| ΔT_{Off} | Switch-off temperature difference | 0.5 ... 29.5 K | 4.0 K |
| ΔT_{Set} | Set temperature difference | 1.5 ... 40.0 K | 10.0 K |
| TMax | Maximum temperature of the store to be loaded | 10 ... 95 °C | 60 °C |
| TMin | Minimum temperature of the store to be discharged | 10 ... 95 °C | 10 °C |
| Timer | Timer function | Yes, No | No |
| Funct. | Activation / Deactivation | Activated, Deactivated, Switch | Activated |
| Sensor | Switch input selection | - | - |
| Save function / Delete function | Save or delete function | - | - |

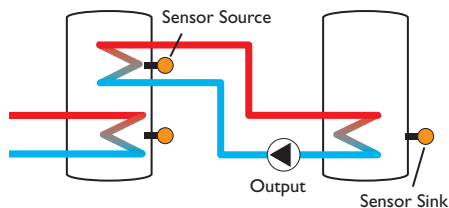

This function can be used for transferring heat from a heat source to a heat sink.

The allocated output is energised when all switch-on conditions are fulfilled:

- the temperature difference between the allocated sensors has exceeded the switch-on temperature difference
- the temperature difference between the allocated sensors has not fallen below the switch-off temperature difference
- the temperature at the heat source sensor has exceeded the minimum temperature
- the temperature at the heat sink sensor is below the maximum temperature
- one of the adjusted time frames is active (if the **Timer** option is selected)

If the temperature difference exceeds the adjusted set value by 1/10 of the rise value, the pump speed increases by one step (1 %).

When the **Timer** option is activated, a timer is indicated in which time frames for the function can be adjusted.



Note

For information on timer adjustment see page 12.

Solid fuel boiler

| | |
|-------------------|----|
| Solid fuel boiler | |
| ► Output | R4 |
| Sen. boiler | S3 |
| Sen. store | S4 |

Arrangement / Opt. functions / Add new function / Solid fuel boiler

| Adjustment channel | Description | Adjustment range / selection | Factory setting |
|--------------------|-------------------------------------|------------------------------|------------------|
| Output | Output selection | system dependent | system dependent |
| Sen. boiler | Solid fuel boiler sensor selection | system dependent | system dependent |
| Sen. store | Store sensor selection | system dependent | system dependent |
| ΔT_{On} | Switch-on temperature difference | 2.0 ... 30.0 K | 6.0 K |
| ΔT_{Off} | Switch-off temperature difference | 1.0 ... 29.0 K | 4.0 K |
| ΔT_{Set} | Set temperature difference | 3.0 ... 40.0 K | 10.0 K |
| TStoremax | Maximum temperature | 10 ... 95 °C | 60 °C |
| TMin boiler | Minimum temperature | 10 ... 95 °C | 60 °C |
| Target temp. | Target temperature option | Yes, No | No |
| Targ. temp. | Target temperature | 30 ... 85 °C | 65 °C |
| Sensor | Target temperature reference sensor | system dependent | system dependent |

| Adjustment channel | Description | Adjustment range/selection | Factory setting |
|---------------------------------|-------------------------------------|--------------------------------|------------------|
| Mixer | Mixer option | Yes, No | No |
| Mixer cl. | Output selection mixer closed | system dependent | system dependent |
| Mixer op. | Output selection mixer open | system dependent | system dependent |
| Sensor | Mixer sensor allocation | system dependent | system dependent |
| ΔT_{Open} | Temperature difference mixer open | 0.5 ... 30.0 K | 5.0 K |
| ΔT_{Closed} | Temperature difference mixer closed | 0.0 ... 29.5 K | 2.0 K |
| Interval | Mixer interval | 1 ... 20 s | 4 s |
| Funct. | Activation / Deactivation | Activated, Deactivated, Switch | Activated |
| Sensor | Switch input selection | - | - |
| Save function / Delete function | Save or delete function | - | - |

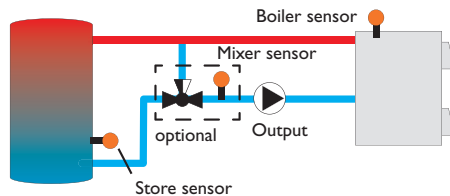

This function can be used for transferring heat from a solid fuel boiler to a store.

The allocated output is energised when all switch-on conditions are fulfilled:

- the temperature difference between the allocated sensors has exceeded the switch-on temperature difference
- the temperature difference between the allocated sensors has not fallen below the switch-off temperature difference
- the temperature at the solid fuel boiler sensor has exceeded the minimum temperature
- the temperature at the store sensor is below the maximum temperature
- one of the adjusted time frames is active (if the **Timer** option is selected)

When the set temperature difference is exceeded, pump speed control starts. For every deviation by 1/10 of the adjusted rise value, the pump speed will be adjusted by 1%.

If the **Target temp.** option is activated, the pump speed control logic will change. The controller will remain at the minimum pump speed until the temperature at the allocated sensor exceeds the adjusted target temperature.

The **Mixer** option can be used to keep the boiler return temperature above **TMin boiler**. The mixer will be controlled with the adjustable interval.

Return preheating

| | |
|---------------|----|
| Ret. preheat. | |
| Output | R4 |
| Sen. return | S4 |
| Sen. source | S3 |

Arrangement / Opt. functions / Add new function / Ret. preheat.

| Adjustment channel | Description | Adjustment range/selection | Factory setting |
|---------------------------------|-----------------------------------|--------------------------------|------------------|
| Output | Output selection | system dependent | system dependent |
| Sen. return | Return sensor selection | system dependent | system dependent |
| Sen. source | Heat source sensor selection | system dependent | system dependent |
| ΔT_{On} | Switch-on temperature difference | 2.0 ... 30.0 K | 6.0 K |
| ΔT_{Off} | Switch-off temperature difference | 1.0 ... 29.0 K | 4.0 K |
| Summer off | Summer switch-off option | Yes, No | No |
| Sensor | Outdoor sensor selection | system dependent | system dependent |
| Toff | Switch-off temperature | 10 ... 60 °C | 20 °C |
| Funct. | Activation / Deactivation | Activated, Deactivated, Switch | Activated |
| Sensor | Switch input selection | - | - |
| Save function / Delete function | Save or delete function | - | - |

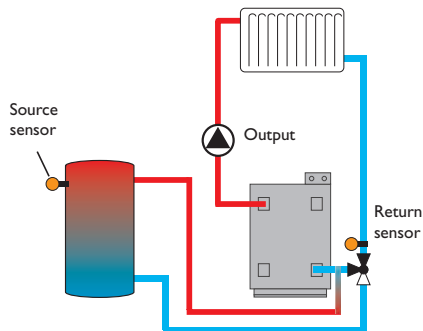

This function can be used for transferring heat from a heat source to the heating circuit return.

The allocated output is energised when all switch-on conditions are fulfilled:

- the temperature difference between the allocated sensors has exceeded the switch-on temperature difference
- the temperature difference between the allocated sensors has not fallen below the switch-off temperature difference
- if **Summer off** is activated, the temperature at the outdoor temperature sensor falls below the adjusted outdoor temperature value

With the summer switch-off option, the return preheating can be suppressed outside the heating period.

Function block

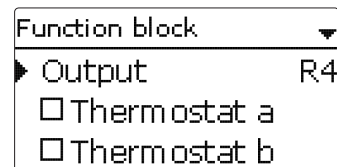

Arrangement / Opt. functions / Add new function / Function block

| Adjustment channel | Description | Adjustment range/selection | Factory setting |
|---------------------|-------------------------------------|----------------------------|------------------|
| Output | Output selection | system dependent | system dependent |
| Thermostat a | Thermostat function a | Yes, No | No |
| Th-a on | Switch-on temperature thermostat a | -40 ... +250 °C | +40 °C |
| Th-a off | Switch-off temperature thermostat a | -40 ... +250 °C | +45 °C |
| Sensor | Sensor thermostat a | system dependent | system dependent |
| Thermostat b | Thermostat function b | Yes, No | No |
| Th-b on | Switch-on temperature thermostat b | -40 ... +250 °C | +40 °C |
| Th-b off | Switch-off temperature thermostat b | -40 ... +250 °C | +45 °C |
| Sensor | Sensor thermostat b | system dependent | system dependent |
| ΔT function | Differential function | Yes, No | No |
| ΔT_{On} | Switch-on temperature difference | 1.0 ... 50.0 K | 5.0 K |
| ΔT_{Off} | Switch-off temperature difference | 0.5 ... 49.5 K | 3.0 K |
| ΔT_{Set} | Set temperature difference | 3 ... 100 K | 10 K |
| Sen. source | Heat source sensor | system dependent | system dependent |
| Sen. sink | Heat sink sensor | system dependent | system dependent |
| Timer | Timer function | Yes, No | No |
| Ref. output | Reference output function | Yes, No | No |
| Mode | Reference output mode | OR, AND, NOR, NAND | OR |
| Output | Reference output 1 | all outputs | - |
| Output | Reference output 2 | all outputs | - |
| Output | Reference output 3 | all outputs | - |
| Output | Reference output 4 | all outputs | - |
| Output | Reference output 5 | all outputs | - |

| Adjustment channel | Description | Adjustment range/selection | Factory setting |
|-------------------------------|---------------------------|--|-----------------|
| Flow rate | Flow rate function | Yes, No | No |
| Fl. on | Switch-on flow rate | 1.0 ... 999.0 l/min | 8.0 l/min |
| Fl. off | Switch-off flow rate | 0.5 ... 998.5 l/min | 7.5 l/min |
| Sen. flow rate | Flow rate sensor | IMP1 ... IMP3, Ga1, Ga2, Gd1, Gd2, FR1 | - |
| Funct. | Activation / Deactivation | Activated, Deactivated, Switch | Activated |
| Sensor | Switch input selection | - | - |
| Save function/Delete function | Save or delete function | - | - |

In addition to the pre-defined optional functions, function blocks consisting of thermostat functions, timer, differential, reference output and flow rate functions are available. With the help of these function blocks, further components and functions respectively can be controlled.

To each function block, sensors and outputs available can be allocated.

Within a function block the functions are interconnected (AND gate). This means that the switching conditions of all the activated functions have to be fulfilled for switching the allocated output. As soon as one condition is not fulfilled, the output will switch off.

Thermostat function

The switching condition for the thermostat function is considered fulfilled when the adjusted switch-on temperature (Th-(x) on) is reached.

The switching condition for the thermostat function is considered unfulfilled when the adjusted switch-off temperature (Th-(x) off) is reached.

Allocate the reference sensor in the **Sensor** channel.

Adjust the maximum temperature limitation with (Th-(x) off) > (Th-(x) on) and the minimum temperature limitation with (Th-(x) on) > (Th-(x) off). The temperatures cannot be set to an identical value.

ΔT function

The switching condition for the ΔT function is considered fulfilled when the adjusted switch-on temperature (ΔT_{on}) is reached.

The switching condition for the ΔT function is no longer considered fulfilled when the adjusted switch-off temperature (ΔT_{off}) is reached.

The ΔT function is equipped with a speed control function. A set temperature difference and a minimum speed can be adjusted. The non-adjustable rise value is 2K.

Reference output

Up to 5 Reference outputs can be selected. Whether the reference outputs are to be switched in series (AND), in parallel (OR), in series + inverted (NAND) or in parallel + inverted (NOR) can be adjusted in the **Mode** channel.

OR mode

If at least one of the reference outputs is switched on, the switching condition for the reference output function is considered fulfilled.

If none of the reference outputs is switched on, the switching condition for the reference output function is considered unfulfilled.

NOR mode

If none of the reference outputs is switched on, the switching condition for the reference output function is considered fulfilled.

If at least one of the reference outputs is switched on, the switching condition for the reference output function is considered unfulfilled.

AND mode

If all reference outputs are switched on, the switching condition for the reference output function is considered fulfilled.

If at least one of the reference outputs is switched off, the switching condition for the reference output function is considered unfulfilled.

NAND mode

If at least one of the reference outputs is switched off, the switching condition for the reference output function is considered fulfilled.

If all reference outputs are switched on, the switching condition for the reference output function is considered unfulfilled.

Flow rate

If the adjusted switch-on flow rate is exceeded, the switching condition for the flow rate function is considered fulfilled.

If the flow rate falls below the adjusted switch-off value, the condition for the flow rate function is no longer considered fulfilled.

The flow rate sensor for this function can be selected.



Note

For information on timer adjustment see page 12.

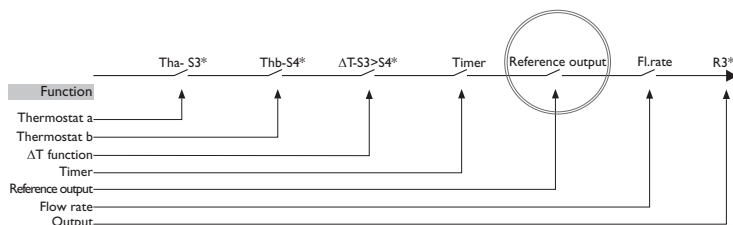

* exemplary selection, sensors and outputs can be freely selected

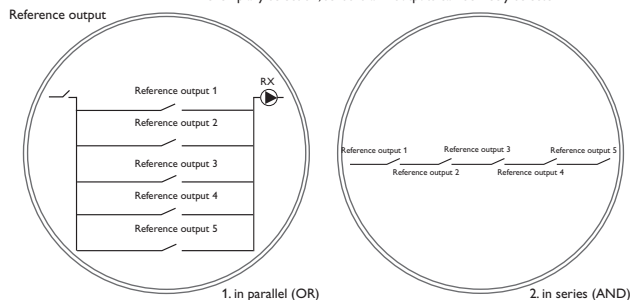

Irradiation switch

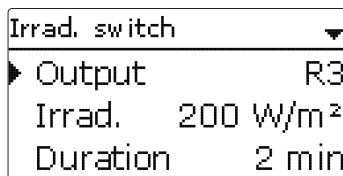

Arrangement / Opt. functions / Add new function / Irrad. switch

| Adjustment channel | Description | Adjustment range/selection | Factory setting |
|---------------------------------|---------------------------|--------------------------------|----------------------|
| Output | Output selection | system dependent | system dependent |
| Irrad. | Switch-on irradiation | 50 ... 1000 W/m ² | 200 W/m ² |
| Duration | Switch-on duration | 0 ... 30 min | 2 min |
| Inverted | Inverted switching option | Yes, No | No |
| Funct. | Activation / Deactivation | Activated, Deactivated, Switch | Activated |
| Sensor | Switch input selection | - | - |
| Save function / Delete function | Save or delete function | - | - |

This function can be used for operating an output depending on the measured irradiation value.

The allocated output will be switched on if the adjusted irradiation value remains exceeded for the adjusted duration. If the irradiation falls below the adjusted irradiation value for the adjusted duration, the output will be switched off. If the **Inverted** option is activated, the output will operate vice versa.

Return mixing function

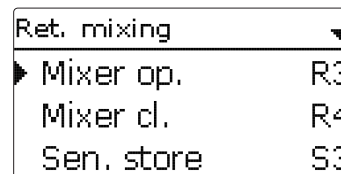

Arrangement / Opt. functions / Add new function / Ret. mixing

| Adjustment channel | Description | Adjustment range/selection | Factory setting |
|---------------------------------|---|--------------------------------|------------------|
| Mixer op. | Output selection mixer open | system dependent | system dependent |
| Mixer cl. | Output selection mixer closed | system dependent | system dependent |
| Sen. store | Store sensor allocation | system dependent | system dependent |
| Sen. HC ret. | HC return sensor allocation | system dependent | system dependent |
| Sen. boiler ret. | Boiler return sensor allocation | system dependent | system dependent |
| ΔTOn | Switch-on temperature difference | 1.0 ... 25.0 K | 5.0 K |
| ΔTOff | Switch-off temperature difference | 0.5 ... 24.0 K | 3.0 K |
| ΔTSet | Set temperature difference | -20 ... +25 K | +7 K |
| TMax | Maximum boiler return temperature | 10 ... 80 °C | 60 °C |
| Interval | Mixer interval | 1 ... 20 s | 2 s |
| HC intern. | Detection controller heating circuit active | Yes, No | No |
| HC intern. | Heating circuit allocation | HC 1...7 | - |
| Runtime | Mixer runtime | 10 ... 600 s | 105 s |
| Time | Time of automatic adjustment | 00:00 ... 23:45 | 00:00 |
| Funct. | Activation / Deactivation | Activated, Deactivated, Switch | Activated |
| Sensor | Switch input selection | - | - |
| Save function / Delete function | Save or delete function | - | - |

This function can be used for solar heating backup.

Solar heat from the store is mixed into the heating circuit return by means of a mixing valve in order to add heat to the heating circuit. The controller compares the temperature at the selected store sensor to the heating circuit return temperature. If the store temperature exceeds the heating circuit return temperature by the switch-on temperature difference, the mixer will be used to add solar heat from the store to the heating circuit return. The mixer will be opened or closed in pulses depending on this deviation. The pulses are determined by the adjustable interval. The pause is determined by the difference between the actual value and the set value. Thus, the heating circuit return temperature increases by the ΔT_{Set} value. The adjustable maximum boiler return temperature limits the mixing temperature. If the store temperature falls below the heating circuit return temperature by the switch-off temperature difference, the mixer will close.

The runtime defines the time needed for the mixer to switch from its initial position to the end position. The **Time** defines the point in time when the mixer is set to its initial or ending position respectively.

HC intern. option

If the **HC intern.** option is activated, the return mixing function will only become active when a selectable heating circuit connected to the same controller is active, too. For this purpose, the heating circuit selected has to be controlled by the controller or by a module connected.

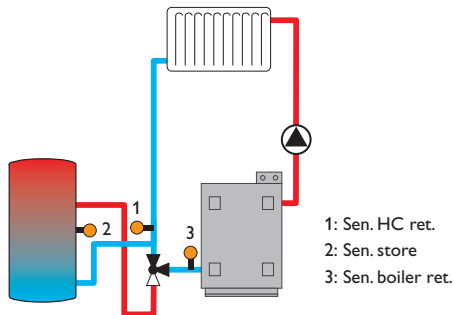

Flow rate monitoring

| | |
|------------------|------|
| Flow rate mon. ▾ | |
| ▶ Sensor | IMP2 |
| Ref. relay | R4 |
| Time | 30 s |

Arrangement / Opt. functions / Add new function / Flow rate mon.

| Adjustment channel | Description | Adjustment range/selection | Factory setting |
|----------------------|----------------------------|--------------------------------|-----------------|
| Sensor | Flow rate sensor selection | system dependent | - |
| Ref. relay | Reference relay selection | system dependent | - |
| Time | Delay time | 1 ... 300 s | 30 s |
| Funct. | Activation / Deactivation | Activated, Deactivated, Switch | Activated |
| Sensor | Switch input selection | - | - |
| Save function/Delete | Save or delete function | - | - |

This function can be used to detect malfunctions that impede the flow rate and to switch off the corresponding output. This will prevent system damage, e.g. through a dry run of the pump.

If the flow rate monitoring function is activated, an error message will appear when no flow rate is detected at the allocated flow rate sensor after the delay time has elapsed.

If a reference relay has been selected, the flow rate monitoring function will become active when the allocated relay switches on. In case of an error, the complete solar system will be shut down.

The error message will appear both in the **Status / Messages** menu and in the **Status / Arrangement / Flow rate mon.** menu. It can be acknowledged in the **Status / Arrangement / Flow rate mon.** menu only.

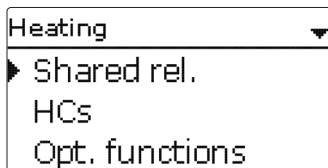

In this menu, all adjustments for the heating part of the arrangement or for the heating circuits respectively can be made.

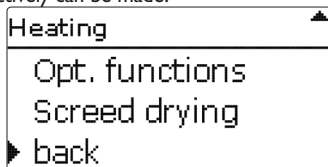

10.1 Shared relays

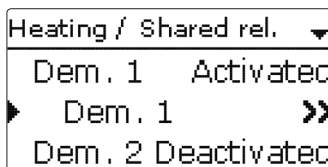

In this menu, adjustments for heat generators which are shared by several heating circuits and their optional functions can be made.

Shared relays will be available for selection under **Virtual** in the heating circuits and in the relay allocation channels of the corresponding optional functions of the heating menu. This way, several heating circuits and optional functions (heating) can demand the same heat source.



Note

Activate and adjust the shared relays first. They will then be available in the heating circuits and optional functions.

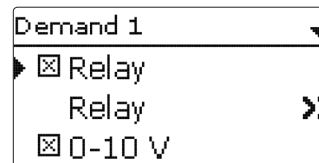

Heating / Shared rel.

| Adjustment channel | Description | Adjustment range/selection | Factory setting |
|--------------------|---------------------------------------|----------------------------|------------------|
| Dem. 1 (2) | Demand 1 (2) | Activated, Deactivated | Deactivated |
| Relay | Relay option | Yes, No | No |
| Relay | Relay submenu | - | - |
| Relay | Relay selection | system dependent | system dependent |
| Boiler pr. min | Option for boiler protection min | Yes, No | No |
| TMin | Minimum boiler temperature | 10 ... 90 °C | 55 °C |
| Boiler pr. max | Option for boiler protection max | Yes, No | No |
| TMax | Maximum boiler temperature | 20 ... 95 °C | 90 °C |
| Sen. boiler | Boiler sensor selection | system dependent | S4 |
| 0-10V | 0-10V option | Yes, No | No |
| 0-10V | 0-10V submenu | - | - |
| Output | Output selection | -, A, B, C, D | - |
| TSet 1 | Lower boiler temperature | 10 ... 85 °C | 10 °C |
| Volt 1 | Lower voltage | 1.0 ... 10.0V | 1.0V |
| TSet 2 | Upper boiler temperature | 15 ... 90 °C | 80 °C |
| Volt 2 | Upper voltage | 1.0 ... 10.0V | 8.0V |
| Permanent volt. | Permanent voltage option | Yes, No | No |
| Volt | Permanent voltage value | 0.1 ... 9.9V | 2.0V |
| TMin | Minimum value set boiler temperature | 10 ... 89 °C | 10 °C |
| TMax | Maximum value set boiler temperature | 11 ... 90 °C | 80 °C |
| ΔTFlow | Increase for the set flow temperature | 0 ... 20K | 5K |
| Sen. flow | Flow sensor option | Yes, No | No |
| Sensor | Flow sensor selection | system dependent | S4 |
| Interval | Monitoring period | 10 ... 600 s | 30 s |
| Hysteresis | Correction hysteresis | 0.5 ... 20.0K | 1.0K |

| Adjustment channel | Description | Adjustment range/se-lection | Factory setting |
|--------------------|--------------------------------------|-----------------------------|------------------|
| Correction | Correction of the voltage signal | 0.0 ... 1.0V | 0.1V |
| Min. runt. | Minimum runtime option | Yes, No | No |
| tMin | Minimum runtime | 0 ... 120 min | 10 min |
| Manual mode | Operating mode for shared relays | Max., Auto, Off, Min. | Auto |
| Pump 1 (2) | Shared relay option for loading pump | Activated, Deactivated | Deactivated |
| Pump 1 (2) | Pump submenu | - | - |
| Output | Output selection | system dependent | system dependent |
| Delay | Pump delay | No, Time, Temp. | No |
| TOn | Boiler start-up temperature | 10 ... 90 °C | 60 °C |
| Duration | Delay to a demand | 0 ... 300 s | 60 s |
| Overrun | Pump overrun | No, Time, Temp. | No |
| TOff | Remaining boiler temperature | 10 ... 90 °C | 50 °C |
| Duration | Delay to a demand | 0 ... 300 s | 60 s |
| Sen. boiler | Boiler sensor selection | system dependent | system dependent |
| Manual mode | Manual mode of output | Max., Auto, Min., Off | Auto |
| Valve 1 (2) | Shared relay option for valve | Activated, Deactivated | Deactivated |
| Valve 1 (2) | Valve submenu | - | - |
| Output | Output selection | system dependent | system dependent |
| Manual mode | Manual mode of output | Max., Auto, Min., Off | Auto |

back

Every demand can be carried out by means of a relay and/or a 0-10V output. If both the **Relay** and the **0-10V** option are activated, the demand uses both outputs in parallel.

Example:

The potential-free relay R14 can be allocated to the shared relay **Dem. 1**, for example. R14 will then become available for potential-free boiler demand in the heating circuits and e.g. the DHW heating function.

Relay option

If the **Relay** option is activated, the submenu **Relay** appears, in which a relay can be allocated to the demand.

The **Boiler pr. min** option is used for protecting a boiler against cooling. If the temperature falls below the adjusted minimum temperature, the allocated relay will be energised until the minimum temperature is exceeded by 5 K.

The **Boiler pr. max** option is used for protecting a boiler against overheating. If the adjusted maximum temperature is exceeded, the allocated relay will be switched off until the temperature falls by 5 K below the maximum temperature.

For this purpose, a boiler sensor is required.

0-10V option

If the **0-10V** option is activated, the submenu **0-10V** appears, in which a 0-10V output can be allocated to the demand.

With this option, the controller can demand modulating heat generators equipped with a 0-10V interface.

The characteristic curve of the 0-10V signal as a function of the set boiler temperature is defined by means of 2 set points according to the specifications of the boiler manufacturer. At a temperature of **TSet 1**, the voltage signal of the heat generator is **Volt 1**. At a temperature of **TSet 2**, the voltage signal of the heat generator is **Volt 2**. The controller automatically calculates the characteristic curve resulting from these values. If the **permanent voltage** option is activated, the parameter **Volt** appears, by means of which a minimum voltage that is permanently applied to the output can be defined.

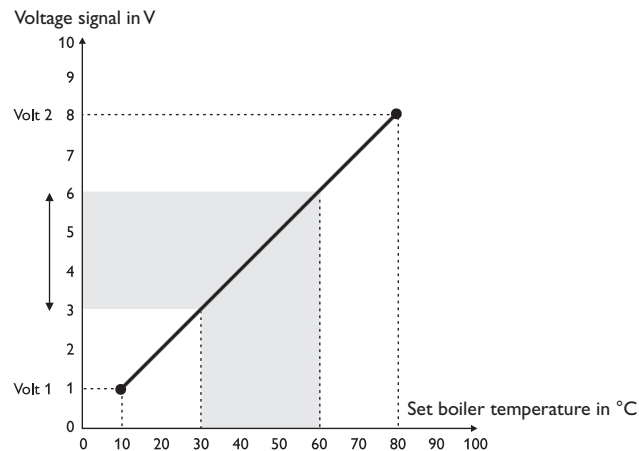

By means of the adjustment channels **TMax** and **TMin** the maximum and minimum values for the set boiler temperature can be defined.

When the **Sen. flow** option is activated, the controller monitors whether the heat generator actually reaches the desired set temperature and, if necessary, adjusts the voltage signal accordingly. In order to do so, the controller checks the temperature at the boiler flow sensor when the interval has elapsed. If the temperature measured deviates from the set boiler temperature by more than the hysteresis, the voltage signal is adapted by the **Correction** value. This process will be repeated until the temperature measured is identical to the set boiler temperature.

When the **Min. runt.** option is activated, a minimum runtime can be adjusted for the demand.

Pump

For loading pumps, the shared relays **Pump 1** and **Pump 2** are available. Concerning a demand, the options **Delay** and **Overrun** can be activated for the shared relays. The demand can either be time- or temperature controlled. For temperature-dependent control an allocated boiler sensor is required.

The **Delay** option is used for switching on the loading pump with a delay to a demand. If the adjusted minimum temperature at the allocated sensor is exceeded or the adjusted duration has elapsed, the allocated output switches on. The **Overrun** option is used for switching off the loading pump with a delay to a demand. If the temperature falls below the adjusted remaining boiler temperature or the adjusted duration has elapsed, the allocated output switches off.

Valve

Valves and parallel relays can use the shared relays **Valve 1** and **Valve 2**. These shared relays are energised individually or along with a reference relay (e.g. loading pump).



Note

If the 0-10V demand is used for DHW heating, the voltage signal will always be identical to **TMax**.

10.2 Heating circuits

The controller has 2 mixed weather-compensated heating circuits and is able to control up to 5 external mixed heating circuits by means of extension modules.

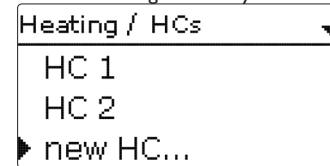

If one or more extension modules are connected, they have to be registered with the controller. Only registered modules will be available in the heating circuit selection.

If **New HC...** is selected for the first time, the first heating circuit is allocated to the controller.

In the heating circuit menu, relays for the heating circuit pump and the heating circuit mixer can be selected.

3 relays are required for a mixed heating circuit.

In the **System** parameter, a selection can be made between **Heat**, **Cool** and **Heat/Cool**.

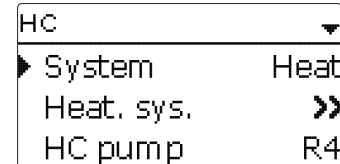

If the measured flow temperature deviates from the set flow temperature, the mixer will be activated in order to adjust the flow temperature correspondingly.

The mixer runtime can be adjusted with the parameter **Interval**.

Heating system submenu

| | |
|--------------|----|
| HC | |
| ▶ Heat. sys. | ➤➤ |
| HC pump | R2 |
| Mixer op. | R3 |

In the **Heating system** submenu, a mode for the heating circuit control can be selected and adjusted. 5 modes are available:

- Constant
- Curve
- Linear
- Room influence
- Room

The calculated set flow temperature is limited by the adjusted values for the maximum flow temperature and the minimum flow temperature.

Maximum flow temperature \geq set flow temperature \geq minimum flow temperature

The remote control allows manual adjustment of the heating curve (± 15 K). Furthermore, the heating circuit can be switched off or a rapid heat-up can be carried out by means of the remote control.

Heating circuit switched off means that the heating circuit pump is switched off and the mixer closed. The flow temperature is boosted to maximum for rapid heat-up when the remote control is set to rapid heat-up.

If the outdoor temperature sensor is defective, an error message will be indicated. For the duration of this condition, the maximum flow temperature -5 K is assumed as the set flow temperature in the **Curve** and **Linear** mode.

By means of the adjustment channels **TFlowmax** and **TFlowmin** the maximum and minimum values for the set flow temperature can be defined.

| | |
|------------|----------|
| Heat. sys. | |
| ▶ Mode | Constant |
| Tflowset | 45 °C |
| Tflowmin | 20 °C |

The **Constant** mode aims to keep the set flow temperature at a constant value which can be adjusted by means of the parameter **TFlowset**.

Set flow temperature = TFlowset + remote control + day correction or night correction

| | |
|------------|-------|
| Heat. sys. | |
| ▶ Mode | Curve |
| Curve | 1.0 |
| Tflowmin | 20 °C |

If the **Curve** mode is selected, the controller calculates a set flow temperature by means of the outdoor temperature and the heating curve selected. In both cases, the dial setting of the remote control and the controller day correction or night correction will be added.

Set flow temperature = heating curve temperature + remote control + day correction or night correction.

Heating curves

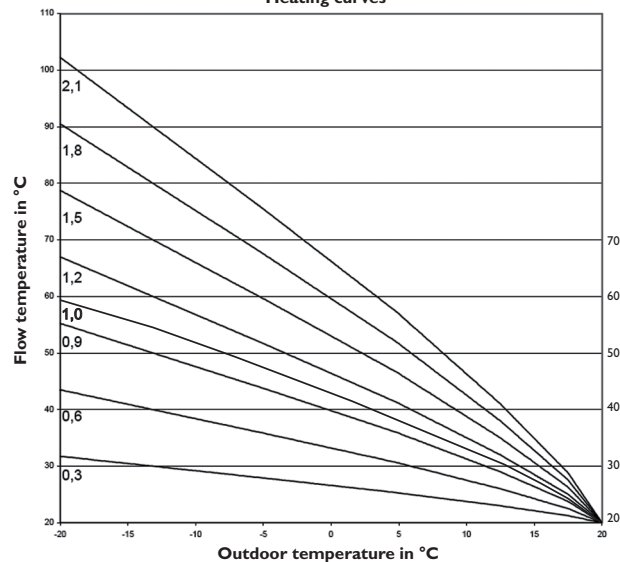

| | |
|--------------|--------|
| Heat. sys. ▾ | |
| ▶ Mode | Linear |
| TOutdoor 1 | 20 °C |
| TFlow 1 | 20 °C |

In the **Linear** mode the flow temperature curve will be calculated depending on the outdoor temperature by 2 points. At a temperature of **TOutdoor 1** the set flow temperature is **TFlow 1**. At a temperature of **TOutdoor 2** the set flow temperature is **TFlow 2**. The controller automatically calculates the characteristic curve resulting from these values.

| | |
|--------------|------------|
| Heat. sys. ▾ | |
| ▶ Mode | Room infl. |
| Curve | 1.0 |
| Room factor | 5 |

In the **Room influence** mode, the weather-compensated set flow temperature will be expanded by a demand-based room control. The parameter **Room factor** can be used for determining the intensity of the room influence.

The controller will calculate the set flow temperature using the heating system Curve plus the room influence: Set flow temperature = set temperature + remote control + day correction or night correction + room influence.

In order to calculate the deviation of the room temperature from the adjusted set value, at least one sensor-type room thermostat is required. The adjustments can be made in the **Room therm.** submenu.

| | |
|--------------|-------|
| Heat. sys. ▾ | |
| ▶ Mode | Room |
| TStart | 40 °C |
| TFlowmin | 20 °C |

In the **Room** mode, the controller will calculate the set flow temperature by means of the room temperature, the outdoor temperature will not be taken into account. Day/Night correction and Timer will not be indicated.

The start value of the set flow temperature can be influenced by the parameter **TStart**.

In order to calculate the deviation of the room temperature from the adjusted set value, at least one sensor-type room thermostat is required (see page 76). The adjustments can be made with the **Room therm. (1 ... 5)** parameter. For this purpose, select **Sensor** in the **Type** adjustment channel.

The adjustments of all activated room thermostats will be taken into account. The controller will calculate the average value of the deviations measured and correct the set flow temperature correspondingly.

Timer

With the **timer**, the day / correction operation can be adjusted. During day phases, the set flow temperature is increased by the adjusted **day correction**.

| | |
|---|-------------|
| HC ▾ | |
| ▶ <input checked="" type="checkbox"/> Timer | Timer |
| Timer | Day / Night |
| <input type="checkbox"/> Summer oper. | Timer |
| | back |

The parameter **Mode** is used for selecting between the following correction modes: **Day/Night**: A reduced set flow temperature (night correction) is used during Night operation.

Day/Off: The heating circuit and the optionally activated backup heating are switched off during night operation.

The **Timer** can be used for adjusting the time frames for day operation.

Summer operation

| | |
|--|----|
| HC ▾ | |
| <input checked="" type="checkbox"/> Summer oper. | |
| ▶ Summer oper. | >> |
| <input type="checkbox"/> Remote access | |

In summer mode, the heating circuit is switched off.

For summer operation, 2 different modes are available:

Day: If the outdoor temperature exceeds the summer temperature day, the heating circuit switches off.

Day/Night: The parameters **Daytime on** and **Daytime off** can be used for adjusting a time frame for the summer operation. If the outdoor temperature exceeds the summer temperature day within the adjusted time frame, the heating circuit switches off.

Outside the adjusted time frame the summer temperature night is valid.

| | |
|----------------|-------------|
| Summer oper. ▾ | |
| ▶ Mode | Day / Night |
| TDay off | 20 °C |
| TNight off | 14 °C |

Remote access

With the parameter **Remote access** different types of remote access to the controller can be activated.

| | |
|-------------------------------------|------------------|
| HC ▾ | |
| <input checked="" type="checkbox"/> | Remote access |
| ▶ | Remote access >> |
| | Room therm. >> |



Note

In the sensor selection menu, only outputs which have previously been selected as the input for remote access in the **Inputs/Modules** menu will be available. In the **Sensor config.** channel, sensors not used and not registered can be selected.

| | |
|---------------|-----|
| Remote access | |
| ▶ Mode | BAS |
| Sen. BAS | S3 |
| back | |

The following types of remote access are possible:

Remote control: A device which allows manual adjustment of the heating curve, thus influencing the set flow temperature.

→ In order to use a remote control, set the **Mode** to **Fern**.

Room control unit: A device incorporating a remote control as well as an additional operating mode switch.

→ In order to use a room control unit, set the **Mode** to **BAS**.

The operating mode switch of the room control unit is used for adjusting the operating mode of the controller. If a room control unit is used, the operating mode can be adjusted by means of the room control unit only. The status menu will only allow the activation of the operating mode **Holiday**.

App: If **App** is selected, remote access as with a remote control or room control unit via an app is possible.

If **Fern** or **BAS** is adjusted, read access is possible with the app.

| | |
|------|--------------------------------------|
| Mode | |
| ▶ | <input checked="" type="radio"/> App |
| | <input type="radio"/> Fern |
| | <input type="radio"/> BAS |

→ In order to use an app, set the **Mode** to **App**.

If you use an app, the operating mode can be adjusted in the controller menu as well as in the app.

Room thermostat option

| | |
|--------------------------|---|
| Room thermostats ▾ | |
| <input type="checkbox"/> | Room therm. 1 |
| <input type="checkbox"/> | Room therm. 2 |
| ▶ | <input checked="" type="checkbox"/> Room therm. 3 |

Up to 5 room thermostats can be integrated into the control logic.

To each room thermostat, a sensor input can be allocated. If the measured temperature exceeds the adjusted set room temperature at all activated room thermostats and if the parameter **HC off** is activated, the heating circuit switches off.

Common room thermostats with potential-free outputs can be used alternatively. In this case, **Switch** must be selected in the **Type** channel.

| | |
|--------------------|----------------|
| Room thermostats ▾ | |
| Type | Sensor |
| ▶ | Sensor RTH S4 |
| | TAmb.set 18 °C |

When the **Timer** option is activated, a timer is indicated in which time frames for the function can be adjusted. Outside these time frames, the adjusted room temperature is decreased by the **Correction** value.

If the heating circuit is in cooling mode, the set room temperature is increased by the **Correction** value.



Note

For information on timer adjustment see page 12.

| | |
|--------------------------------|-----|
| Room thermostats | |
| <input type="checkbox"/> Timer | |
| Correction | 5 K |
| ▶ Output | R4 |

To each room thermostat, an additional output can be allocated. The output switches on when the temperature falls below the adjusted room temperature. This way, the room in question can be excluded from the heating circuit via a valve as long as the desired room temperature is reached.

| | |
|---|----|
| RTH1 HC 1 | |
| ▶ <input checked="" type="checkbox"/> Relay | |
| Relay | R4 |
| <input type="checkbox"/> PWM/0-10 V | |

Backup heating

For the backup heating of the heating circuit, 3 modes are available:

Therm.: In this mode, the set flow temperature is compared to a store reference sensor.

Zone: In this mode, the set flow temperature is compared to 2 store reference sensors. The switching conditions have to be fulfilled at both reference sensors.

On/Off: In this mode, the backup heating is activated when the heating circuit pump is switched on for heating.

| | |
|----------------|-------|
| Backup heating | |
| Mode | Zone |
| ▶ Output | Dem.1 |
| Sensor 1 | S4 |

In the **Output** submenu, the modes **Standard** and **Demand** are available. If **Standard** is selected, the output can be adjusted.

| | |
|-------------------------------------|----------|
| BH HC 1 | |
| ▶ Mode | Standard |
| <input type="checkbox"/> Relay | |
| <input type="checkbox"/> PWM/0-10 V | |

If **Demand** is selected, a demand has to be activated and adjusted in the **Heating / Shared rel.** menu first. If **Adj. values** is selected, the **Heating / Shared rel. / Demand** menu will open.

| | |
|-------------|--------|
| BH HC 1 | |
| ▶ Mode | Demand |
| Output | Dem.1 |
| Adj. values | ➤➤ |

In the correction mode **Day/Off** (see page 75) the heating circuit and the backup heating is completely switched off during the night operation. The starting optimisation can be used for activating the backup heating before the day operation in order to heat the store to a sufficiently high temperature. The stopping optimisation can be used for deactivating the backup heating before the start of the night operation.

| | |
|--------------------------------------|----|
| Backup heating | |
| ▶ Loading pump | R4 |
| <input type="checkbox"/> Start. opt. | |
| <input type="checkbox"/> Stopp. opt. | |

If **Solar off** is activated, backup heating is suppressed when an adjusted store is being loaded.

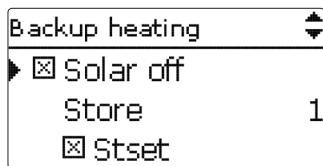

If the **Stset** option is activated, the backup heating is only suppressed when the store temperature exceeds the set store temperature.

If **SFB off** is activated, backup heating is suppressed when a selected solid fuel boiler is active.

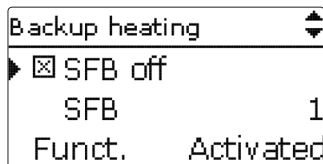

DHW priority

If the parameter **DHW priority** is activated, the heating circuit will be switched off and the backup heating be suppressed as long as DHW heating takes place which has previously been activated in the **Heating / Optional functions** menu.

Chimney sweeper function

The chimney sweeper function can be used for enabling a quick access to measurement conditions without menu operation for the chimney sweeper.

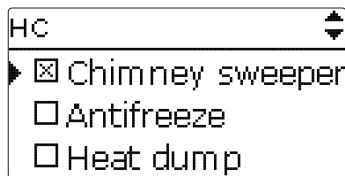

The chimney sweeper function is activated in all heating circuits by default. The chimney sweeper mode can be activated by pressing button **6** for 5s

In the chimney sweeper mode, the heating circuit mixer opens, the heating circuit pump and the backup heating contact are activated. While the chimney sweeper mode is active, the directional pad is flashing red. Additionally, **Chimney sweeper** and a countdown of 30 min are indicated on the display.

When the countdown has elapsed, the chimney sweeper mode is automatically deactivated. If, during the countdown, button **6** is again pressed for more than 5 s, the chimney sweeper mode will stop.

Antifreeze function

The antifreeze function of the heating circuit can be used to temporarily activate an inactive heating circuit during sudden temperature drop in order to protect it against frost damage.

The temperature at the sensor selected will be monitored. If the temperature falls below the adjusted antifreeze temperature, the heating circuit will be activated until the antifreeze temperature is exceeded by 2 K, but at least for 30 min.

Heat dump option

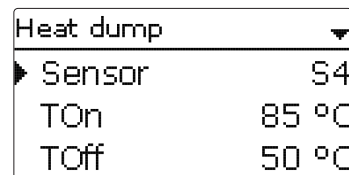

This option is used for diverting excess heat to the heating circuit in order to keep the system temperatures within the operating range. If the temperature at the allocated sensor exceeds the switch-on temperature, the set flow temperature is controlled to reach the adjusted value. If the temperature falls below the adjusted switch-off temperature, the heat dump function switches off.

This option is not available, if a heating circuit mode for cooling or cooling and heating has been selected.

Cooling

In the **Cooling system** submenu, the cooling logic can be adjusted.

For the cooling logic, 2 modes are available:

- Linear
- Constant

| Cooling system | Cooling system |
|---|---|
| <input checked="" type="checkbox"/> Mode Constant | <input checked="" type="checkbox"/> Mode Linear |
| TFlow 20 °C | TOutdoor 1 20 °C |
| TFlowmin 10 °C | TFlow 1 20 °C |

In the **Linear** mode, the set flow temperature will be calculated as in the heating system mode **Linear**.

The **Constant** mode aims to keep the set flow temperature at a constant value which can be adjusted by means of the parameter **TFlow**.

For activating cooling, 3 modes are available:

- Outdoor
- External switch
- Both

| Mode | |
|----------------------------------|-------------|
| <input type="radio"/> | both |
| <input type="radio"/> | Ext. switch |
| <input checked="" type="radio"/> | Outdoor |

In the **Outdoor** mode, cooling is activated if the outdoor temperature cooling is exceeded.

In the **Ext. switch** mode, cooling is activated by means of an external switch.

In the **both** mode, both switching conditions are valid for cooling.

If the **Timer** option is activated, a time frame can be adjusted in which the cooling will be active.

Dew point

| Dew point | |
|----------------------------------|----------|
| <input type="radio"/> | Humidity |
| <input type="radio"/> | Switch |
| <input checked="" type="radio"/> | Off |

The **Dew point** option is used for avoiding condensation. For this function, 3 variants are available:

- Humidity
- Switch
- Off

| HC | |
|-------------|----------|
| ▶ Dew point | Humidity |
| Sensor | Ga1 |
| Correction | 2 K |

When **Humidity** is selected, the controller calculates the dew point by means of the humidity sensor.

The minimum flow temperature results from the dew point plus the adjustable correction value. The **emergency shutdown** option is used for switching off the cooling, if the adjustable relative humidity is exceeded. The re-energise hysteresis for this function can be adjusted. An output can be selected which is activated during an emergency shutdown, e.g. to switch on a fan.

| HC | |
|---|-----|
| ▶ <input checked="" type="checkbox"/> Emerg. shutd. | |
| Humidity | 95% |
| Hysteresis | 5% |

| HC | |
|-------------|--------|
| ▶ Dew point | Switch |
| Sensor | S3 |
| Output | R4 |

When **Switch** is selected, an input as well as an output can be allocated to a dew point switch. If the dew point switch detects condensation, cooling is interrupted.

If **Off** is selected, the **dew point** option is switched off.

If the **Holiday** option is activated, the heating circuit switches into the correction mode.

➔ In order to adjust the days of absence, press and hold down button  for 5 s.

Energy saving operation

| Energy saving | |
|---------------|--------|
| ▶ Sen. return | S4 |
| ΔTOff | 4 K |
| Break | 15 min |

This option is used for optimising the energy consumption of the heating circuit pump. For this purpose an additional sensor in the heating circuit return is required. The controller monitors the temperature difference between the flow and the return of the heating circuit. If the temperature difference falls below the switch-

off difference, the controller deactivates the heating circuit pump for the adjusted break time. After the break time has elapsed, the pump is activated for the runtime. If the temperature difference is higher than the switch-off difference, the pump remains active. If the temperature difference is below the switch-off difference, the break time starts again.

Heating / HCs / new HC... / Internal or Module 1...5

| Adjustment channel | Description | Adjustment range/se-lection | Factory setting |
|--------------------|---------------------------------------|---|------------------|
| System | Heating circuit mode selection | Heat, Cool, Heat/ Cool | Heat |
| Heat. sys. | Heating system submenu | - | - |
| Mode | Heating system operating mode | Linear, Constant, Curve, Room, Room infl. | Curve |
| Curve | Heating curve | 0.3 ... 3.0 | 1.0 |
| Room factor | Room influence factor | 1 ... 10 | 5 |
| TFlowset | Set flow temperature | 10 ... 90 °C | 45 °C |
| TOutdoor 1 | Lower outdoor temperature | -20 ... +20 °C | +20 °C |
| TFlow 1 | Lower set flow temperature | 20 ... 90 °C | 20 °C |
| TOutdoor 2 | Upper outdoor temperature | -20 ... +20 °C | -20 °C |
| TFlow 2 | Upper set flow temperature | 20 ... 90 °C | 70 °C |
| TStart | Start temperature | 20 ... 60 °C | 40 °C |
| TFlowmin | Minimum flow temperature | 20 ... 89 °C | 20 °C |
| TFlowmax | Maximum flow temperature | 21 ... 90 °C | 50 °C |
| Interval | Mixer interval | 1 ... 20 s | 4 s |
| HC pump | Heating circuit pump output selection | system dependent | system dependent |
| Mixer op. | Output selection mixer open | system dependent | system dependent |
| Mixer cl. | Output selection mixer closed | system dependent | system dependent |
| Sen. flow | Flow sensor selection | system dependent | system dependent |
| Sen. outd. | Outdoor sensor selection | system dependent | system dependent |
| Day corr. | Correction for day operation | -5 ... +45 K | 0 K |
| Night corr. | Correction for night operation | -20 ... +30 K | -5 K |
| Timer | Timer function correction mode | Yes, No | No |
| Mode | Correction mode | Day/Night, Day/Off | Day/Night |
| Timer | Timer function submenu | - | - |
| Summer oper. | Summer operation option | Yes, No | No |
| Summer oper. | Summer operation submenu | - | - |
| Mode | Summer operating mode | Day/Night, Day | Day |
| TDay off | Summer temperature day | 0 ... 40 °C | 20 °C |
| TNight off | Summer temperature night | 0 ... 40 °C | 14 °C |

| Adjustment channel | Description | Adjustment range/se-lection | Factory setting |
|---------------------|--|--------------------------------|------------------|
| Daytime on | Day time frame on | 00:00 ... 23:45 | 09:00 |
| Daytime off | Day time frame off | 00:00 ... 23:45 | 21:00 |
| Remote access | Remote access option | Yes, No | No |
| Remote access | Remote access submenu | - | - |
| Mode | Remote access mode | BAS, Fern, App | BAS |
| Sen. BAS | Allocation operating mode switch input | all inputs type = BAS | - |
| Sen. RC | Allocation remote control input | all inputs type = Fern | - |
| Room therm. | Room thermostats submenu | - | - |
| Room therm. 1 ... 5 | Room thermostat option (1 ... 5) | Yes, No | No |
| Type | Room thermostat type selection | Sensor, Switch | Sensor |
| Sensor RTH | RTH input allocation | system dependent | system dependent |
| TAmb.set | Set room temperature | 10 ... 30 °C | 18 °C |
| Hysteresis | RTH hysteresis | 0.5 ... 20.0 K | 0.5 K |
| Timer | RTH timer function | Yes, No | No |
| Correction | Correction value | 1 ... 20 K | 5 K |
| Output | Output selection | system dependent | system dependent |
| RTH | Room thermostat | Activated, Deactivated, Switch | Activated |
| HC off | Heating circuit off option | Yes, No | Yes |
| Backup heating | Backup heating option | Yes, No | No |
| Backup heating | Backup heating submenu | - | - |
| Mode | Backup heating mode selection | Therm., Zone, On/Off | Therm. |
| Output | Output selection | system dependent | system dependent |
| Sensor 1 | Allocation reference sensor 1 | system dependent | system dependent |
| Sensor 2 | Allocation reference sensor 2 (When mode = Zone) | system dependent | system dependent |
| ΔTON | Switch-on temperature difference | -15.0 ... 44.5 K | 5.0 K |
| ΔTOFF | Switch-off temperature difference | -14.5 ... 45.0 K | 15.0 K |
| Loading pump | Boiler loading pump output selection | system dependent | system dependent |
| Start. opt. | Starting optimisation option | Yes, No | No |
| Time | Starting optimisation time | 0 ... 300 min | 60 min |
| Stopp. opt. | Stopping optimisation option | Yes, No | No |
| Time | Stopping optimisation time | 0 ... 300 min | 60 min |
| Solar off | Solar off option | Yes, No | No |

| Adjustment channel | Description | Adjustment range/se-lection | Factory setting |
|--------------------|----------------------------------|--|---------------------------------|
| Store | Allocation solar store | all solar stores | - |
| Stset | Set temperature option | Yes, No | No |
| SFB off | Solid fuel boiler off option | Yes, No | No |
| SFB | Allocation solid fuel boiler | all solid fuel boilers | - |
| DHW priority | DHW priority option | Yes, No | No |
| Chimney sweeper | Chimney sweeper option | Yes, No | Yes |
| Antifreeze | Antifreeze option | Yes, No | No |
| Sensor | Antifreeze sensor | Flow, Outdoor | Flow |
| TAntifr. | Antifreeze temperature | -20... +10 °C (Outdoor) 4... 10 °C (Flow) | +2 °C (Outdoor) +5 °C (Flow) |
| TFlowset | Set flow temperature antifreeze | 20... 50 °C | 20 °C |
| Heat dump | Heat dump option | Yes, No | No |
| Heat dump | Heat dump submenu | - | - |
| Sensor | Allocation heat dump sensor | system dependent | system dependent |
| TOon | Switch-on temperature heat dump | 25... 95 °C | 85 °C |
| TOff | Switch-off temperature heat dump | 20... 90 °C | 50 °C |
| TFlowset | Set flow temperature heat dump | 5... 90 °C | 50 °C |
| Cooling system | Cooling system submenu | - | - |
| Mode | Cooling mode | Linear, Constant | Constant |
| TFlow | Cooling flow temperature | 5... 25 °C | 20 °C |
| TFlowmin | Minimum flow temperature | 5... 29 °C | 10 °C |
| TOutdoor 1 | Lower outdoor temperature | 15... 45 °C | 20 °C |
| TFlow 1 | Lower set flow temperature | 5... 25 °C | 20 °C |
| TOutdoor 2 | Upper outdoor temperature | 15... 45 °C | 40 °C |
| TFlow 2 | Upper set flow temperature | 5... 25 °C | 10 °C |
| TFlowmin | Minimum flow temperature | 5... 29 °C | 10 °C |
| TFlowmax | Maximum flow temperature | 6... 30 °C | 25 °C |
| Output | Output selection | system dependent | system dependent |
| Mode | Cooling mode | Outdoor, Ext. switch, both | - |
| Sensor | Switch input selection | - | - |
| Inverted | Inverted switching option | Yes, No | No |
| TDay off | Outdoor temperature cooling | 20... 40 °C | 20 °C |
| Timer | Timer function cooling | Yes, No | No |
| tOn | Switch-on time cooling | 00:00... 23:45 | 00:00 |
| tOff | Switch-off time cooling | 00:00... 23:45 | 00:00 |

| Adjustment channel | Description | Adjustment range/se-lection | Factory setting |
|---------------------------------|---|--------------------------------|------------------|
| Dew point | Dew point monitoring option | Humidity, Switch, Off | Off |
| Sensor | Sensor input selection | system dependent | system dependent |
| Correction | Correction value | 0... 10 K | 2 K |
| Emerg. shutd. | Emergency shutdown option | Yes, No | No |
| Humidity | Relative humidity | 5... 100% | 95% |
| Hysteresis | Re-energise hysteresis | 1... 10% | 5% |
| Output | Output selection | system dependent | system dependent |
| Holiday | Heating circuit off when holiday function is active | Yes, No | No |
| Energy saving | Energy saving operation option | Yes, No | No |
| Energy saving | Energy saving operation submenu | - | - |
| Sen. return | HC return sensor allocation | system dependent | system dependent |
| ΔTOff | Switch-off temperature difference energy saving operation | 1... 49 K | 4 K |
| Break | Break time energy saving operation | 0... 60 min | 15 min |
| Runtime | Runtime energy saving operation | 0... 60 min | 2 min |
| Func. | De/activation of the heating circuit | Activated, Deactivated, Switch | Activated |
| Sensor | Switch input selection | - | - |
| Save function / Delete function | Save or delete function | - | - |

10.3 Optional functions

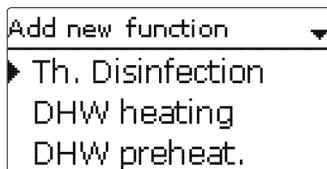

In this menu, optional functions can be selected and adjusted for the heating part of the arrangement.

The kind and number of optional functions offered depends on the previous adjustments.

In the **Demand** submenu, the modes **Standard** and **Demand** are available. If **Standard** is selected, the output can be adjusted.

If **Demand** is selected, a demand has to be activated and adjusted in the **Heating / Shared rel.** menu first.



Note

For further information about adjusting optional functions, see page 14.



Note

For information on the output selection see page 16.

Thermal disinfection

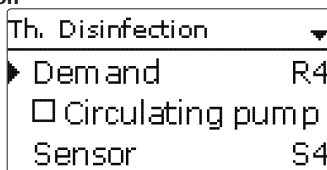

Heating / Opt. functions / Add new function / Th. Disinfection

| Adjustment channel | Description | Adjustment range/selection | Factory setting |
|--------------------|-----------------------------------|----------------------------|------------------|
| Demand | Demand relay selection | system dependent | system dependent |
| Circulating pump | Circulating pump option | Yes, No | No |
| Output | Circulating pump output selection | system dependent | system dependent |
| Sensor | Disinfection sensor selection | system dependent | system dependent |

| Adjustment channel | Description | Adjustment range/selection | Factory setting |
|-------------------------------|--|--------------------------------|------------------|
| Interval | Monitoring period | 0 ... 30, 1 ... 23 (dd:hh) | 1d 0h |
| Temperature | Disinfection temperature | 45 ... 90 °C | 60 °C |
| Duration | Disinfection period | 0.5 ... 24.0 h | 1.0 h |
| Cancellation | Cancellation option | Yes, No | No |
| Cancellation | Cancellation interval | 1.0 ... 48.0 h | 2.0 h |
| Start. time | Starting delay option | Yes, No | No |
| Start. time | Starting time | 00:00 ... 23:30 | 20:00 |
| Hyst. off | Switch-off hysteresis | 2 ... 20K | 5K |
| Hyst. on | Switch-on hysteresis | 1 ... 19K | 2K |
| TD hold. off | Thermal disinfection off when holiday function is active | Yes, No | No |
| BAS off | Operating mode switch off option | Yes, No | No |
| Sensor | Allocation operating mode switch input | system dependent | system dependent |
| Funct. | Activation / Deactivation | Activated, Deactivated, Switch | Activated |
| Sensor | Switch input selection | - | - |
| Save function/Delete function | Save or delete function | - | - |

This function helps to contain the spread of Legionella in DHW stores by systematically activating the backup heating.

One sensor and one output respectively can be selected for this function.

For thermal disinfection, the temperature at the allocated sensor has to be monitored. Protection is ensured when, during the monitoring period, the disinfection temperature is continuously exceeded for the entire disinfection period.

The monitoring period starts as soon as the temperature at the allocated sensor falls below the disinfection temperature. If the monitoring period ends, the demand activates the backup heating. The disinfection period starts when the temperature at the allocated sensor exceeds the disinfection temperature.

Thermal disinfection can only be completed when the disinfection temperature is exceeded for the duration of the disinfection period without any interruption.

The parameter **Cancellation** is used for adjusting the period after which the backup heating is cancelled. If the backup heating is cancelled, an error message is displayed. Thermal disinfection is cancelled.

Starting time delay

If the starting delay option is activated, a starting time for the thermal disinfection with starting delay can be adjusted. The activation of the backup heating is then delayed until that starting time after the monitoring period has ended.

If the monitoring period ends, for example, at 12:00 o'clock, and the starting time has been set to 18:00, the reference relay will be energised with a delay of 6 hours at 18:00 instead of 12:00 o'clock.

With the **TD hold. off** option, thermal disinfection can be deactivated for a phase of absence.

➔ In order to adjust the days of absence, press and hold down button 7 for 5 s.

DHW heating

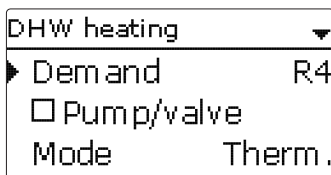

Heating / Opt. functions / Add new function / DHW heating

| Adjustment channel | Description | Adjustment range / selection | Factory setting |
|--------------------|---|------------------------------|------------------|
| Demand | Output selection demand | system dependent | - |
| Mode | Demand mode | Standard, Demand | Standard |
| Pump/valve | Loading pump/valve option | Yes, No | No |
| Output | Output selection loading pump | system dependent | - |
| Overrun time | Overrun option | Yes, No | No |
| Duration | Overrun time | 1 ... 10 min | 1 min |
| Mode | Operating mode | Zone, Therm. | Therm. |
| Sensor 1 | Allocation reference sensor 1 | system dependent | system dependent |
| Sensor 2 | Allocation reference sensor 2 (if mode = Zone) | system dependent | system dependent |
| TOn | Switch-on temperature | 0 ... 94 °C | 40 °C |
| TOff | Switch-off temperature | 1 ... 95 °C | 45 °C |
| Timer | Timer function | Yes, No | No |
| Man. heating | Manual heating option | Yes, No | No |
| Sensor | Switch input selection | system dependent | system dependent |
| DHW hold. off | DHW heating off when holiday function is active | Yes, No | No |

| Adjustment channel | Description | Adjustment range / selection | Factory setting |
|-------------------------------|--|--------------------------------|------------------|
| BAS off | Operating mode switch off option | Yes, No | No |
| Sensor | Allocation operating mode switch input | system dependent | system dependent |
| Solar off | Solar off option | Yes, No | No |
| Store | Allocation solar store | all solar stores | - |
| Stset | Set temperature option | Yes, No | No |
| SFB off | Solid fuel boiler off option | Yes, No | No |
| SFB | Allocation solid fuel boiler | all solid fuel boilers | - |
| Funct. | Activation / Deactivation | Activated, Deactivated, Switch | Activated |
| Sensor | Switch input selection | - | - |
| Save function/Delete function | Save or delete function | - | - |

This function is used for demanding backup heating for heating the DHW store.

If the **Pump/valve** option is activated, another adjustment channel appears, in which an output can be allocated to the pump/valve. The allocated output will switch on and off with the demand relay.

If the **Overrun** time option is activated, the loading pump remains switched on for the adjusted duration after the demand relay has been switched off.

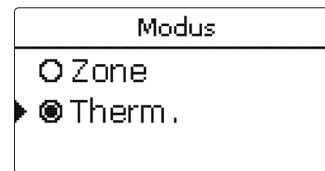

For the DHW heating, 2 modes are available:

Thermal mode

The allocated demand relay switches on when the temperature at the allocated sensor 1 falls below the adjusted switch-on temperature. If the temperature at the allocated sensor 1 exceeds the adjusted switch-off temperature, the relay switches off.

Zone mode

In this mode, a further sensor can be selected. The switch-on, or the switch-off conditions respectively, then have to be fulfilled at both sensors in order for the output to be switched on or off.

When the **Timer** option is activated, a timer is indicated in which time frames for the function can be adjusted.



Note

For information on timer adjustment see page 12.

If **SFB off** is activated, DHW heating is suppressed when a selected solid fuel boiler is active.

If **Solar off** is activated, backup heating is suppressed when a previously adjusted store is being loaded.

If the **Stset** option is activated, the backup heating is only suppressed when the store temperature exceeds the set store temperature.

With the **Man. heating** option, DHW heating can be activated outside the adjusted time frame once by means of a switch, if the temperature has fallen below the switch-off value.

With the **DHW holid. off** option, DHW heating can be deactivated for a phase of absence.

➔ In order to adjust the days of absence, press and hold down button for 5 s.

With the **BAS off** option, DHW heating can be switched from automatic mode to off by means of the operating mode switch.

DHW preheating

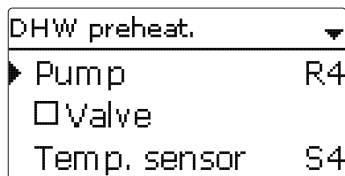

Heating / Opt. functions / Add new function / DHW preheat.

| Adjustment channel | Description | Adjustment range/selection | Factory setting |
|--------------------|------------------------|----------------------------|-----------------|
| Pump | Output selection pump | system dependent | - |
| Valve | Valve option | Yes, No | No |
| Valve | Output selection valve | system dependent | - |

| Adjustment channel | Description | Adjustment range/selection | Factory setting |
|---------------------------------|-----------------------------------|--|-----------------|
| Temp. sensor | Temperature sensor | system dependent | - |
| Sen. flow rate | Flow rate sensor | IMP1 ... IMP3, Ga1, Ga2, Gd1, Gd2, FR1 | - |
| TMax DHW | DHW maximum temperature | 20 ... 90 °C | 60 °C |
| Start. speed | Starting speed DHW preheating | 20 ... 100% | 50% |
| Increment | Increment speed adaptation | 1 ... 100% | 10% |
| Hysteresis | Hysteresis speed adaptation | 0.5 ... 10.0 K | 5.0 K |
| Delay | Delay time | 1 ... 10 s | 5 s |
| ΔT function | Activation ΔT function | Yes, No | No |
| ΔTOn | Switch-on temperature difference | 1.0 ... 50.0 K | 5.0 K |
| ΔTOff | Switch-off temperature difference | 0.5 ... 49.5 K | 3.0 K |
| Sen. source | Heat source sensor selection | system dependent | - |
| Sen. sink | Heat sink sensor selection | system dependent | - |
| Funct. | Activation / Deactivation | Activated, Deactivated, Switch | Activated |
| Sensor | Switch input selection | - | - |
| Save function / Delete function | Save or delete function | - | - |

This function uses heat from a buffer store to heat the cold water inlet of the DHW store.

The controller monitors the flow rate at the selected flow rate sensor. If a flow rate is detected, the pump switches on with the starting speed.

If the temperature at the temperature sensor selected exceeds the adjusted DHW maximum temperature, the speed decreases by the **Increment** value. The interval to the next measurement and adaptation can be adjusted by means of the parameter **Delay**.

If the DHW maximum temperature is not reached after the delay time has elapsed, the speed is increased by the increment value. The speed is not increased or decreased respectively within the hysteresis.

If the **ΔT function** is activated, the pump switches on only if **ΔTOn** is exceeded, and switches off if the temperature difference falls below **ΔTOff**.

If the **Valve** option is activated, the output selected is activated when the pump is activated.

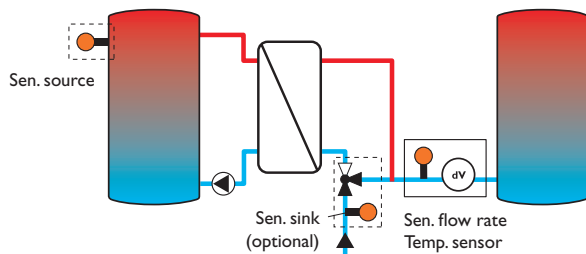

Circulation

| | |
|-------------|---------|
| Circulation | |
| Output | R4 |
| Type | Thermal |
| Sensor | S4 |

Heating / Opt. functions / Add new function / Circulation

| Adjustment channel | Description | Adjustment range/selection | Factory setting |
|---------------------------------|------------------------------|--|------------------|
| Output | Output selection | system dependent | system dependent |
| Type | Variant | Demand, Thermal, Timer, Therm.+Timer, Dem.+Timer | Thermal |
| Sensor | Circulation sensor selection | system dependent | system dependent |
| TO _n | Switch-on temperature | 10 ... 59 °C | 40 °C |
| TO _{ff} | Switch-off temperature | 11 ... 60 °C | 45 °C |
| Timer | Timer function | Yes, No | No |
| Delay | Demand switch-on delay | 0 ... 3 s | 0 s |
| Runtime | Circulation pump runtime | 01:00 ... 15:00 min | 03:00 min |
| Break time | Circulation pump break time | 10 ... 60 min | 30 min |
| Funct. | Activation / Deactivation | Activated, Deactivated, Switch | Activated |
| Sensor | Switch input selection | - | - |
| Save function / Delete function | Save or delete function | - | - |

The **Circulation** function can be used for controlling a circulation pump.

For the control logic, 5 variants are available:

- Thermal
- Timer
- Thermal + Timer
- Demand
- Demand + Timer

Thermal

The temperature at the allocated sensor is monitored. The allocated output switches on when the temperature falls below the adjusted switch-on temperature. If the temperature exceeds the switch-off temperature, the output switches off.

Timer

The output switches on during the adjusted time frames, outside of them it switches off.

Thermal + Timer

The output operates when the switch-on conditions of both above-mentioned variants are fulfilled.

Demand

The allocated flow switch is monitored for circuit continuity. If circuit continuity is detected at the flow switch, the output switches on for the adjusted runtime. After the runtime has ended, the output switches off. During the adjusted break time, the output remains switched off even if continuity is detected at the flow switch.

Demand + Timer

The output operates when the switch-on conditions of both above-mentioned variants are fulfilled.

When the **Timer**, **Therm.+Timer** or **Dem.+Timer** variant is activated, a timer is indicated in which time frames for the function can be adjusted.



Note

If the flow switch is connected to the input S1 ... S12, continuity must be detected for at least 5 s for the controller to react, 1 s if the flow switch is connected to an impulse input.



Note

For information on timer adjustment see page 12.

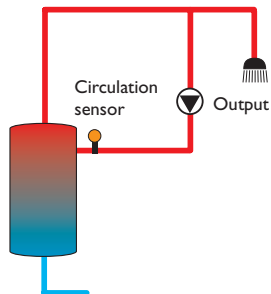

10.4 Screed drying

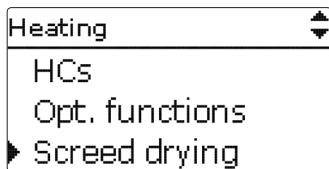

Heating / Screed drying

| Adjustment channel | Description | Adjustment range / selection | Factory setting |
|--------------------|---------------------------|------------------------------|------------------|
| HCs | Heating circuit selection | HC 1...7 | system dependent |
| TStart | Start temperature | 10 ... 30 °C | 20 °C |
| TMax | Holding temperature | 20 ... 60 °C | 30 °C |
| Rise | Rise value | 1 ... 10K | 2K |
| Rise time | Rise duration | 1 ... 24 h | 24 h |
| tBacking | TMax holding time | 1 ... 20 d | 5 d |
| Start | Activation / Deactivation | Yes, No | No |

This function is used for time- and temperature-controlled screed drying in selectable heating circuits.

The heating circuits can be selected in the **Heating / Screed drying** menu. At the end of this menu, the function can be triggered by using **Start**.

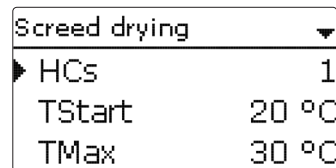

The controller will automatically change to the screed drying status menu. The current **Phase** will be indicated on the display and the **Remaining time** will be indicated as a countdown (dd:hh). During this process, the directional pad flashes green.

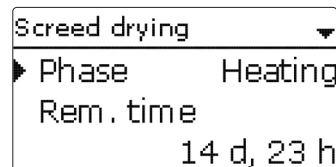

At the end of the menu, **Cancel** will be indicated instead of start. If **Cancel** is selected, screed drying will be cancelled immediately.

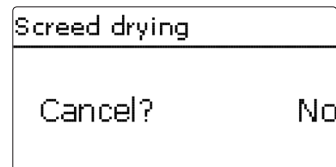

At the beginning of the screed drying function, the heating circuits selected are put into operation for the adjusted rise time with the start temperature as the set flow temperature. Afterwards, the set flow temperature increases in steps by the adjustable rise value for the duration of the adjustable rise time until the holding temperature is reached. After the holding time has elapsed, the set flow temperature is reduced in steps until the start temperature is reached again.

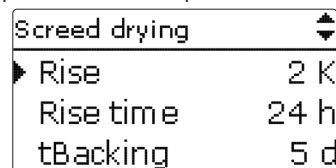

If the set flow temperature is not reached within 24 hours or after the rise time

respectively, or if it is constantly exceeded, the screed drying function will be cancelled.

The heating circuit switches off and an error message is displayed. The directional pad glows red.

Error 1: flow sensor defective

Error 2: the flow temperature is higher than the maximum flow temperature + 5 K for over 5 min

Error 3: the flow temperature is higher than the holding temperature + rise value for over 30 min

Error 4: the flow temperature is higher than the set flow temperature + rise value for over 2 h

Error 5: the flow temperature is lower than the set flow temperature - rise value for over a rise time period

During screed drying of the heating circuits selected, the other heating circuits run corresponding to their operating modes.

Button  can be used any time for changing to the status or main menu of the controller in order to carry out adjustments.

When the screed drying function has been successfully completed, the corresponding heating circuits will change to their operating modes selected.

Screed drying will automatically be deactivated. The chimney sweeper function will be activated in all heating circuits.



Note

Make sure the heating circuits are supplied with heat from a heat source (backup heating).



Note

If an SD card has been inserted into the slot, a screed protocol will be generated.

11 HQM

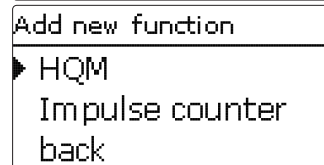
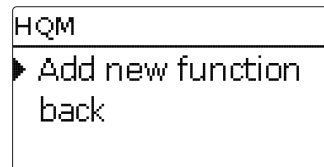

In the **HQM** menu, up to 7 internal heat quantity measurements and up to 3 impulse counters can be activated and adjusted.



Note

The adjustment of the functions is similar to the adjustment of optional functions, see page 14.

Calorimeter

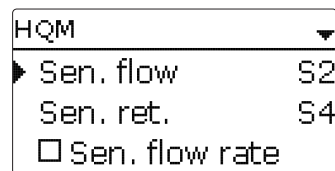

HQM /Add new function /HQM

| Adjustment channel | Description | Adjustment range/selection | Factory setting |
|--------------------|---|--|------------------|
| Sen. flow | Flow sensor selection | system dependent | system dependent |
| Sen. ret. | Return sensor selection | system dependent | system dependent |
| Sen. flow rate | Flow rate sensor option | Yes, No | No |
| Sen. flow rate | Flow rate sensor selection | IMP1 ... IMP3, Ga1, Ga2, Gd1, Gd2, FR1 | - |
| Fl.rate | Flow rate (only if Sen. flow rate = No) | 1.0 ... 500.0 l/min | 3.0 l/min |
| Relay | Relay selection | system dependent | - |

| Adjustment channel | Description | Adjustment range/selection | Factory setting |
|---------------------------------|--|--|-----------------|
| Fluid type | Heat transfer fluid | Tyfocon LS, Propylene glycol, Ethylene glycol, Water | Water |
| Concentr. | Glycol concentration in the heat transfer fluid (only if fluid type = propylene glycol or ethylene glycol) | 20 ... 70% | 40% |
| Alternative unit | Alternative unit option | Yes, No | No |
| Unit | Alternative display unit | Coal, Gas, Oil, CO ₂ | CO ₂ |
| Factor | Conversion factor | 0.0000001 ... 100.0000000 | 0.5000000 |
| Carryover | Carryover value (for the first-time configuration or after a HQM reset only) | - | - |
| Funct. | Activation / Deactivation | Activated, Deactivated, Switch | Activated |
| Sensor | Switch input selection | - | - |
| Save function / Delete function | Save or delete function | - | - |

If the flow rate sensor option is activated, an impulse input or, if available, a Grundfos Direct Sensor™ or a flow rate sensor with frequency signal can be selected. The flow rate sensors with frequency signal and the Grundfos Direct Sensors™ will only be available if they have been previously registered in the **Inputs/Modules** menu. The impulse rate must be adjusted in that menu as well.

If the flow rate sensor option is deactivated, the controller calculates the heat quantity by means of a fixed flow rate value. This is called heat quantity balancing. For this purpose, the flow rate must be read from the flowmeter at 100% pump speed and adjusted in the adjustment channel **Fl.rate**. In addition to that, a relay must be allocated. Heat quantity balancing is in effect whenever the allocated relay is active.

In the adjustment channel **Fluid type** the heat transfer fluid must be selected. If either propylene glycol or ethylene glycol is selected, the adjustment channel **Concentration** is indicated in which the antifreeze ratio of the heat transfer fluid can be adjusted.

If a calorimeter is being configured for the first time or after the overall quantity has been reset, the parameter **Carryover** appears. A former value which is to be added to the overall quantity, can be entered.

When the **Alternative unit** is activated, the controller converts the heat quantity into the quantity of fossil fuels (coal, oil or gas) saved, or the CO₂ emission saved respectively. The alternative unit can be selected. A conversion factor must be adjusted for the calculation. The conversion factor depends on the arrangement in use and has to be determined individually.

Impulse counter

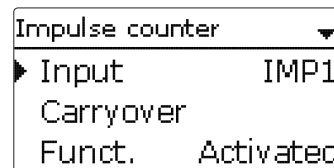

HQM / Add new function / Impulse counter

| Adjustment channel | Description | Adjustment range/selection | Factory setting |
|---------------------------------|--|--------------------------------|-----------------|
| Input | Impulse input | IMP1 ... IMP3 | - |
| Carryover | Carryover value (for the first-time configuration or after a reset only) | - | - |
| Funct. | Activation / Deactivation | Activated, Deactivated, Switch | Activated |
| Sensor | Switch input selection | - | - |
| Save function / Delete function | Save or delete function | - | - |

With an impulse counter, the impulses of a device with S0 output can be counted, e.g. for balancing the yield of a PV system.

For this purpose, one of the impulse inputs of the controller has to be selected in the **Input** channel. If an impulse counter is being configured for the first time or after the overall quantity has been reset, the parameter **Carryover** appears. A former value which is to be added to the overall quantity can be entered.

12 Basic settings

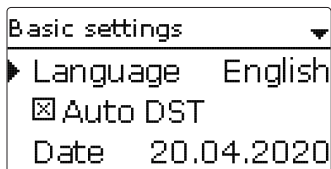

Basic settings

| Adjustment channel | Description | Adjustment range/se- lection | Factory setting |
|--------------------|-----------------------------------|--|-----------------|
| Language | Selection of the menu language | Deutsch, English, Français, Italiano, Español, Nederlands, Suomi | Deutsch |
| Auto DST | Daylight savings time selection | Yes, No | Yes |
| Date | Adjustment of the date | 01.01.2001 ... 31.12.2050 | 01.01.2020 |
| Time | Adjustment of the current time | 00:00 ... 23:59 | - |
| Temp. unit | Temperature unit | °C, °F | °C |
| Vol. unit | Volume unit | Gallons, Litre | Litre |
| Press. unit | Pressure unit | psi, bar | bar |
| Energy unit | Energy unit | kWh, MBTU | kWh |
| Blocking protect. | Blocking protection submenu | - | - |
| Start. time | Blocking protection starting time | 00:00 ... 23:59 | 12:00 |
| Runtime | Blocking protection runtime | 1 ... 30 s | 10 s |
| Reset | back to factory setting | Yes, No | No |
| Scheme | Scheme selection | 0000 ... 9999 | 0000 |

In the **Basic settings** menu, all basic parameters for the controller can be adjusted. Normally, these settings have been made during commissioning. They can be subsequently changed in this menu.

13 SD card

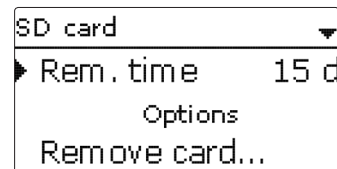

SD card

| Adjustment channel | Description | Adjustment range/se- lection | Factory setting |
|--------------------|--------------------|---------------------------------|-----------------|
| Remove card... | Safely remove card | - | - |
| Save adjustments | Save adjustments | - | - |
| Load adjustments | Load adjustments | - | - |
| Logging int. | Logging interval | 00:01 ... 20:00 (mm:ss) | 01:00 |
| Logging type | Logging type | Cyclic, Linear | Linear |

The controller is equipped with an SD card slot for SD memory cards.

With an SD card, the following functions can be carried out:

- Logging measurement and balance values. After the transfer to a computer, the values can be opened and visualised, e.g. in a spreadsheet.
- Store adjustments and parameterisations on the SD card and, if necessary, retrieve them from there.
- Running firmware updates on the controller.

Firmware updates

The current software can be downloaded from www.resol.com/firmware. When an SD card with a firmware update is inserted, the enquiry **Update?** is indicated on the display.

→ To run the update, select **Yes** and confirm by pressing button .

The update will run automatically. The indication **Please wait...** and a progress bar will appear on the display. When the update has been completed, the controller will automatically reboot and run a short initialisation phase.



Note

Only remove the card when the initialisation phase has been completed and the main menu is indicated on the controller display!

→ To skip the update, select **No**.

The controller starts normal operation.

**Note**

The controller will only recognise a firmware update file if it is stored in a folder named **RESOL** on the first level of the SD card.

→ Create a folder named **RESOL** on the SD card and extract the downloaded ZIP file into this folder.

Starting the logging

- Insert the SD card into the slot.
- Adjust the desired logging type and interval.

Logging will start immediately.

Completing the logging process

- Select the menu item **Remove card...**
- After **Remove card** is displayed, remove the card from the slot.

When **Linear** is adjusted in the logging type adjustment channel, data logging will stop if the capacity limit is reached. The message **Card full** will be displayed.

If **Cyclic** is adjusted, the oldest data logged onto the SD card will be overwritten as soon as the capacity limit is reached.

**Note**

Because of the increasing size of the data packets, the remaining logging time does not decrease linearly. The data packet size can increase, e.g. with the increasing operating hours value.

Storing controller adjustments

- To store the controller adjustments on the SD card, select the menu item **Save adjustments**.

While the adjustments are being stored, first **Please wait....**, then **Done!** will be indicated on the display. The controller adjustments are stored as a .SET file on the SD card.

Loading controller adjustments

- To load controller adjustments from an SD card, select the menu item **Load adjustments**.

The **file selection** window will appear.

- Select the desired .SET file.

While the adjustments are being loaded, first **Please wait....**, then **Done!** will be indicated on the display.

**Note**

To safely remove the SD card, always select the menu item **Remove card...** before removing the card.

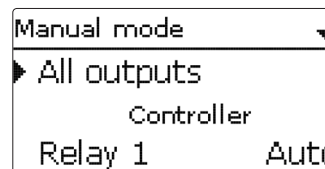
14 Manual mode**Manual mode**

| Adjustment channel | Description | Adjustment range/selection | Factory setting |
|--------------------|--|----------------------------|-----------------|
| All outputs... | Selection operating mode of all relays | Auto, Off | Off |
| Relay 1...X | Operating mode of relay | On, Auto, Off | Auto |
| Output A...D | Operating mode of signal output | On, Max., Auto, Min., Off | Auto |
| Demand 1 (2) | Operating mode of demand | Max., Auto, Min., Off | Auto |
| Pump 1 (2) | Operating mode of pump | Max., Auto, Min., Off | Auto |
| Valve 1 (2) | Operating mode of valve | Max., Auto, Min., Off | Auto |

In the **Manual mode** menu, the operating mode of all outputs in the controller and in modules connected can be adjusted.

In the **All outputs...** menu, all outputs can be switched off (Off) or set to automatic mode (Auto) at once:

Off = Output is switched off (manual mode)

Auto = Output is in automatic mode

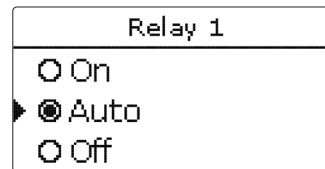

The operating mode can be selected for each individual output, too. The following options are available:

Off = Output is switched off (manual mode)

On = Output is active at 100% speed (manual mode)

Auto = Output is in automatic mode

Min. = Output is active at minimum speed (manual mode)

Max. = Output is active at maximum speed (manual mode)



Note

After service and maintenance work, the relay mode must be set back to **Auto**. In manual mode the control logic is overridden.

15 User code

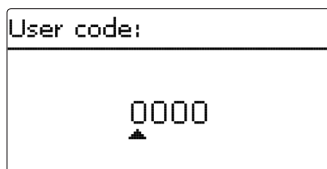

In the **User code** menu, a user code can be entered. Each number of the 4-digit code must be individually adjusted and confirmed. After the last digit has been confirmed, the menu automatically jumps to the superior menu level.

To access the menu areas of the installer level, the installer user code must be entered:

Installer: 0262

For safety reasons, the user code should generally be set to the customer code before the controller is handed to the customer!

Customer: 0000

16 Inputs/Modules

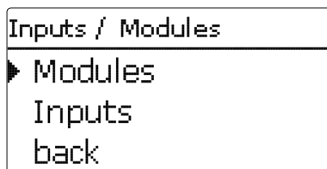

In the **Inputs/Modules** menu, external modules can be registered and sensor offsets be adjusted.

16.1 Modules

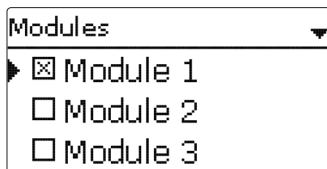

In this menu, up to 5 external modules can be registered.

All modules connected and acknowledged by the controller are available.

→ To register a module, select the corresponding menu item by pressing button

5.

The checkbox indicates the selection. If a module is registered, all its sensor inputs and relay outputs will be available in the corresponding controller menus.

Inputs/Modules/Modules

| Adjustment channel | Description | Adjustment range/selection | Factory setting |
|--------------------|------------------------------|----------------------------|-----------------|
| Module 1 ... 5 | Registering external modules | - | - |

16.2 Inputs

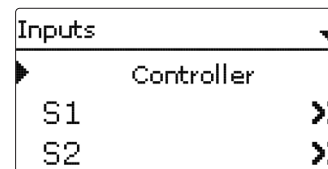

In this submenu, the type of the sensor connected can be adjusted for each individual input. The following types can be selected:

- S1 ... S12: Switch, Fern (remote control), BAS (operating mode switch), Pt1000, Pt500, KTY, None
- S13/IMP1 ... S15/IMP3: Impulse, Switch, Fern (remote control), BAS (operating mode switch), Pt1000, Pt500, KTY, None
- CS10: A ... K
- Ga1, Ga2: RH, RPS, VFS, None
- Gd1, Gd2: RHD, RPD, VFD, None
- FR1: VTY20MA, DN20, DN25, DN32, None

ATTENTION! System damage!



Selecting the wrong sensor type will lead to unwanted control behaviour. In the worst case, system damage can occur!

→ **Make sure that the right sensor type is selected!**

If **KTY**, **Pt500** or **Pt1000** is selected, the channel **Offset** will appear, in which an individual offset can be adjusted for each sensor.

→ In order to select a sensor for the offset adjustment, select the corresponding menu item by pressing button (5).

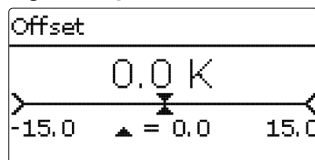

→ To adjust the sensor offset, select the desired value by pressing buttons (2) or (4), then confirm by pressing button (5).



Note

If a sensor is used as the temperature sensor of a function, the sensor types **Switch**, **Fern**, **BAS**, **Impulse** and **none** will not be available for the corresponding input.

ATTENTION! Damage to the device!



Sensor inputs which have been set to the sensor type switch can only be used for connecting potential-free switches.

→ **Make sure no voltage is applied!**

If **switch** is selected, the **inverted** option will appear and can be used for inverting the behaviour of the switch.

CS sensor offset

If a CS10 irradiation sensor is to be connected, an offset has to be carried out before the connection is made.

To carry out the offset, proceed as follows:

→ Adjust the CS type in the **Type** channel.

→ Select the **Offset** channel.

→ Confirm the **Reset?** enquiry with **Yes**.

→ Select **back** to return to the **Inputs** menu, then connect the CS sensor.



Note

When Grundfos Direct Sensors™ are used, connect the sensor ground common terminal block to PE (see page 7).

Inputs/Modules/Inputs

| Adjustment channel | Description | Adjustment range/selection | Factory setting |
|--------------------|---|--|-----------------|
| S1 ... S12 | Sensor input selection | - | - |
| Type | Sensor type selection | Switch, Fern, BAS, KTY, Pt500, Pt1000, None | Pt1000 |
| Offset | Sensor offset | -15.0 ... +15.0K | 0.0K |
| IMP1 ... IMP3 | Impulse input selection | - | - |
| Type | Sensor type selection | Impulse, Switch, Fern, BAS, KTY, Pt500, Pt1000, None | Impulse |
| Inverted | Switch inversion (only when Type = Switch) | Yes, No | No |
| Vol./Imp. | Impulse rate (only when Type = Impulse) | 0.1 ... 100.0 l | 1.0 l |
| CS10 | CS10 input | - | - |
| Type | CS type | A ... K | E |
| Offset | Delete offset | Yes, No | No |
| Ga1, 2 | Analogue Grundfos Direct Sensor™ 1, 2 | - | - |
| Type | Grundfos-Direct-Sensor™ type | RPS,VFS, RH, None | None |
| Max. | Maximum pressure (if Type = RPS) | 0.0 ... 16.0 bar | 6 bar |
| Min. | Minimum flow rate (if Type = VFS) | 1 ... 399 l/min | 2 l/min |
| Max. | Maximum flow rate (if Type = VFS) | 2 ... 400 l/min | 40 l/min |
| Offset | Sensor offset | -15.0 ... +15.0K | 0.0K |
| Gd1, 2 | Digital Grundfos Direct Sensor™ 1, 2 | - | - |
| Type | Grundfos-Direct-Sensor™ type | RPD,VFD, RHD, None | None |
| Offset | Sensor offset | -15.0 ... +15.0K | 0.0K |
| | if Type = VFD: Measuring range selection | 2-40 l/min, 2-40 l/min (fast), 1-12 l/min* | 1-12 l/min |
| FR1 | Frequency input | - | - |
| Type | Sensor type selection | DN20, DN25, DN32, VTY20MA, None | None |

* For the Inputs Gd1 and Gd2, the following sensor combinations are possible:

- 1 x RPD, 1 x VFD
- 2 x VFD, but with different measuring ranges only
- 1 x VFD, 1 x RHD
- 1 x RPD, 1 x RHD

17 Troubleshooting

If a malfunction occurs, a message will appear on the display of the controller.

WARNING!

Danger of electric shock!

Upon opening the housing, live parts are exposed!

→ **Always disconnect the device from power supply before opening the housing!**



The controller is protected by a fuse. The fuse holder (which also holds the spare fuse) becomes accessible when the cover is removed. To replace the fuse, pull the fuse holder from the base.

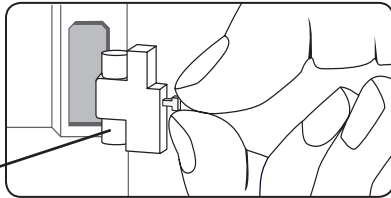

Fuse

Directional pad flashes red.

Sensor fault. The message **!Sensor fault** instead of a temperature is shown on the sensor display channel.

Short circuit or line break.
Disconnected temperature sensors can be checked with an ohmmeter. Please check if the resistance values correspond with the table.

| °C | °F | Ω Pt500 | Ω Pt1000 | Ω KTY | °C | °F | Ω Pt500 | Ω Pt1000 | Ω KTY |
|-----|-----|---------|----------|-------|-----|-----|---------|----------|-------|
| -10 | 14 | 481 | 961 | 1499 | 55 | 131 | 607 | 1213 | 2502 |
| -5 | 23 | 490 | 980 | 1565 | 60 | 140 | 616 | 1232 | 2592 |
| 0 | 32 | 500 | 1000 | 1633 | 65 | 149 | 626 | 1252 | 2684 |
| 5 | 41 | 510 | 1019 | 1702 | 70 | 158 | 636 | 1271 | 2778 |
| 10 | 50 | 520 | 1039 | 1774 | 75 | 167 | 645 | 1290 | 2874 |
| 15 | 59 | 529 | 1058 | 1847 | 80 | 176 | 655 | 1309 | 2971 |
| 20 | 68 | 539 | 1078 | 1922 | 85 | 185 | 664 | 1328 | 3071 |
| 25 | 77 | 549 | 1097 | 2000 | 90 | 194 | 674 | 1347 | 3172 |
| 30 | 86 | 559 | 1117 | 2079 | 95 | 203 | 683 | 1366 | 3275 |
| 35 | 95 | 568 | 1136 | 2159 | 100 | 212 | 693 | 1385 | 3380 |
| 40 | 104 | 578 | 1155 | 2242 | 105 | 221 | 702 | 1404 | 3484 |
| 45 | 113 | 588 | 1175 | 2327 | 110 | 230 | 712 | 1423 | 3590 |
| 50 | 122 | 597 | 1194 | 2413 | 115 | 239 | 721 | 1442 | 3695 |

The display is permanently off.

Press button **5**. Display illuminated?

no

yes

Controller has been in standby, everything OK

Check the power supply of the controller. Is it disconnected?

no

yes

The fuse of the controller could be blown. The fuse holder (which holds the spare fuse) becomes accessible when the cover is removed. The fuse can then be replaced.

Check the supply line and reconnect it.



Note

For answers to frequently asked questions (FAQ) see www.resol.com.

Pump is overheated, but no heat transfer from the collector to the store, flow and return have the same temperature; perhaps also bubbling in the lines.

Air or gas bubbles in the system?
no yes

Is the collector circuit blocked at the dirt trap?
yes

Vent the system; increase the system pressure to a static primary pressure of at least plus 0.5 bar; if necessary continue to increase pressure; switch the pump on and off for a short time.

Clean dirt trap

Pump starts up very late.

Switch-on temperature difference ΔT_{On} too large?
no yes

Non-ideal position of the collector sensor (e.g. flatscrew sensor instead of sensor in immersion sleeves).
yes

Change ΔT_{On} and ΔT_{Off} correspondingly.

Activate tube collector function if necessary.
o.k.

Pump starts for a short moment, switches off, switches on again, etc.

Temperature difference at the controller too small?
no yes

Wrong position of collector sensors?
no yes

Plausibility control of the option tube collector special function

Change ΔT_{On} and ΔT_{Off} correspondingly.
no o.k.

Mount the collector sensor at solar flow (warmest collector output); use immersion sleeve of the respective collector.

The temperature difference between store and collector increases enormously during operation; the collector circuit cannot dissipate the heat.

Collector circuit pump defective?
no yes

Heat exchanger calcified?
no yes

Heat exchanger blocked?
no yes

Heat exchanger too small?
yes

Check / replace it

Decalcify it

Clean it

Replace with correctly sized one.

The solar circuit pump does not work, although the collector is considerably warmer than the store.

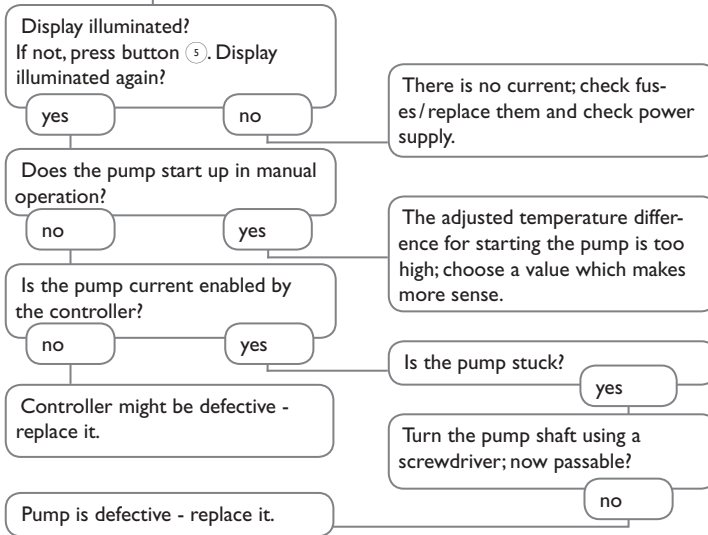

Stores cool down at night.

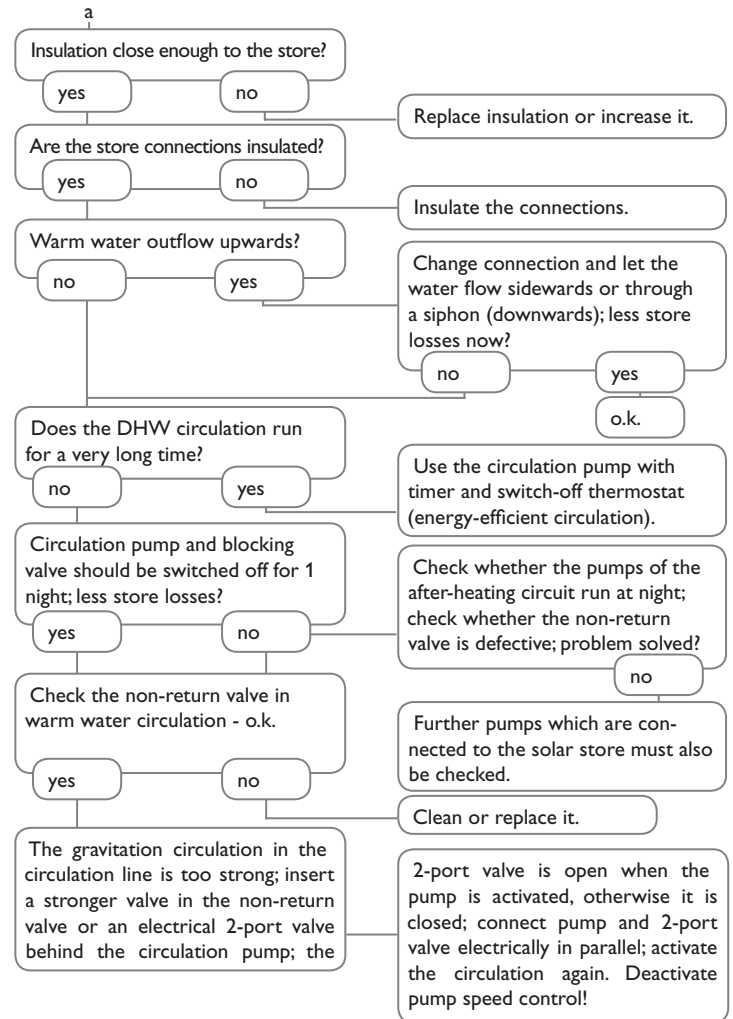
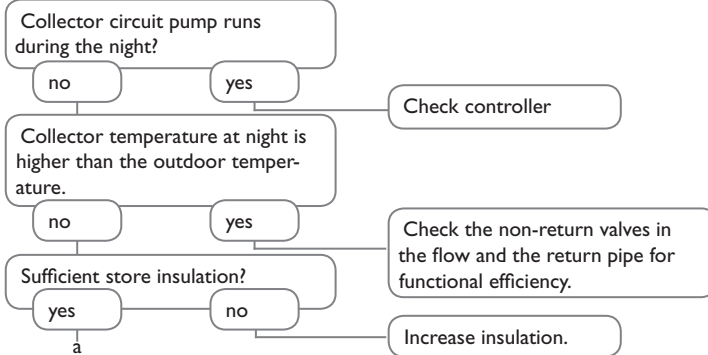



DL3 Datalogger

For visualisation via VBus.net, incl. SD card, mains adapter, network and VBus® cable.



DL2 Datalogger

For visualisation via VBus.net, incl. SD card and network cable, mains adapter and VBus® cable pre-connected.



EM Extension Module

Sensor and relay Extension module with 5 outputs and 6 inputs



FRH (analogue) and FRHd (digital) humidity sensor

The FRH / FRHd is used for measuring the relative humidity and the room temperature.



TS10 Dew point switch

For condensation detection in a heating circuit used for cooling purposes.



VFS/RPS & VFD/RPD Grundfos Direct Sensors™
Analogue / digital sensors in different versions



V40 Flowmeter

The V40 is a measuring instrument for detecting the flow of water or water/glycol mixtures.



AM1 Alarm module

Alarm module for signalling system failures



SD3 / SDFK Smart Display / GA3 Large Display

The SD3 Smart Display is used for visualising data issued by the controller: collector temperature, store temperature and energy yield of the solar thermal system.

The SDFK Smart Display indicates the solid fuel boiler temperature and the bottom/top store temperatures as well as the pump status.

The GA3 is a completely mounted large display module for visualisation of collector- and store temperatures as well as the heat quantity yield of the solar system.





SP10 Overvoltage protection device

Overvoltage protection device, suitable for mounting outdoors.



VBus®/USB, VBus®/LAN, VBus®/Modbus and VBus®/BACnet interface adapters

With the RESOL VBus®/USB interface adapter, the controller can be connected to the USB port of a PC via the VBus®.

The VBus®/LAN interface adapter is designed for the direct connection of the controller to a PC or router.

It enables easy access to the controller via the local network of the owner.

The VBus®/Modbus interface adapter is designed for the connection of the controller to a local network for communication via Modbus TCP/IP.

The VBus®/BACnet interface adapter is designed for the connection of the controller to a local network for communication via BACnet/IP.



Sensors

The product range includes high-precision platinum temperature sensors, flatscrew sensors, outdoor temperature sensors, indoor temperature sensors, cylindrical clip-on sensors, also as complete sensors with immersion sleeve.

Symbols

ΔT function..... 68

Numbers

0-10V boiler control..... 72

A

Antifreeze function..... 78

Antifreeze, solar optional function..... 54

App 76

B

Backup heating, heating circuit..... 77

Backup heating suppression..... 55

Boiler control..... 71

Bypass, solar optional function..... 51

C

Calorimeter 87

Chimney sweeper function..... 78

Circulation 66

Collector cooling, Cooling mode..... 56

Collector emergency shutdown..... 48

Collector emergency temperature..... 48

Collector minimum limitation..... 48

Commissioning menu..... 19

Controller adjustments, loading of..... 90

Cooling mode 56

Cooling system..... 78

Correction modes 77

Countdown 78

CS bypass..... 52

D

Data logging..... 90

Day correction..... 74

Day/Night operation 75

Day operation 77

Dew point..... 79

DHW priority, heating circuit 78

Drainback option 56

E

Electrical connection..... 7

Energy saving operation, heating circuit..... 79

Error messages 46

Error messages, acknowledgement of..... 46

Error relay..... 64

F

Flow rate monitoring 59

Function block 67

Fuse, replacing of..... 93

H

Heat dump..... 58

Heating circuit mixer..... 73

Heating circuit pump..... 73

Heating curve..... 74

HE pump 8

Holiday function 61

I

Interval..... 73

Irradiation switch 69

| | | |
|--|--------|---|
| M | | |
| Manual mode..... | 90 | Solid fuel boiler..... 65 |
| Maximum flow temperature..... | 74 | Spreaded loading..... 50 |
| Maximum store temperature..... | 48 | Starting time..... 77 |
| Minimum flow temperature..... | 74 | Start temperature..... 86 |
| Mixer, optional arrangement function..... | 63 | Store cooling, Cooling mode..... 56 |
| Mixer runtime..... | 73 | Store sequence control..... 49, 50 |
| Modulating heating control..... | 72 | Storing controller adjustments..... 90 |
| Modules, registration of..... | 91 | Successive loading..... 50 |
| Mounting..... | 5 | System cooling, Cooling mode..... 60 |
| N | | |
| Night correction..... | 74 | T |
| Night operation..... | 75 | Target temperature, solar optional function..... 54 |
| O | | |
| Offset..... | 92 | Technical data..... 4 |
| Operating mode, outputs..... | 91 | Thermal disinfection..... 82 |
| Operating mode switch..... | 76 | Thermostat function..... 68 |
| Output selection..... | 16, 18 | Timer..... 12 |
| P | | |
| Parallel relay, solar optional function..... | 55 | Tube collector function..... 53 |
| Priority logic..... | 48 | Twin pump..... 57 |
| R | | |
| Registering external modules..... | 91 | U |
| Remote access, heating circuit..... | 76 | User code..... 91 |
| Remote control..... | 74, 76 | V |
| Return mixing function..... | 69 | VBus®..... 9 |
| Return preheating..... | 66 | Virtual..... 71 |
| Room control, heating circuit..... | 75 | Z |
| Room control unit..... | 76 | Zone loading..... 64 |
| S | | |
| Screed drying..... | 86 | |
| Sensor offset..... | 92 | |
| Set flow temperature..... | 74 | |
| Set store temperature..... | 48 | |
| Shared relays..... | 71 | |

Distributed by:

RESOL – Elektronische Regelungen GmbH

Heiskampstraße 10
45527 Hattingen / Germany

Tel.: +49 (0) 23 24 / 96 48 - 0

Fax: +49 (0) 23 24 / 96 48 - 755

www.resol.com

info@resol.com

Important note

The texts and drawings in this manual are correct to the best of our knowledge. As faults can never be excluded, please note:

Your own calculations and plans, under consideration of the current standards and directions should only be basis for your projects. We do not offer a guarantee for the completeness of the drawings and texts of this manual - they only represent some examples. They can only be used at your own risk. No liability is assumed for incorrect, incomplete or false information and / or the resulting damages.

Note

The design and the specifications can be changed without notice.
The illustrations may differ from the original product.

Imprint

This mounting- and operation manual including all parts is copyrighted. Another use outside the copyright requires the approval of **RESOL – Elektronische Regelungen GmbH**. This especially applies for copies, translations, micro films and the storage into electronic systems.

© **RESOL – Elektronische Regelungen GmbH**